

# Review for Final Exam

**MULTIPLE CHOICE.** Choose the one alternative that best completes the statement or answers the question.

**Determine whether the relation represents a function. If it is a function, state the domain and range.**

1)  $\{(-3, -6), (0, 4), (4, 2), (6, -2)\}$

A) function

domain:  $\{-6, 4, 2, -2\}$

range:  $\{-3, 0, 4, 6\}$

B) function

domain:  $\{-3, 0, 4, 6\}$

range:  $\{-6, 4, 2, -2\}$

C) not a function

1) \_\_\_\_\_

**Find the value for the function.**

2) Find  $f(x + h)$  when  $f(x) = 2x^2 + 4x - 1$ .

A)  $2x^2 + 2h^2 + 8x + 8h - 1$

B)  $2x^2 + 2xh + 2h^2 + 4x + 4h - 1$

C)  $2x^2 + 2h^2 + 4x + 4h - 1$

D)  $2x^2 + 4xh + 2h^2 + 4x + 4h - 1$

2) \_\_\_\_\_

**Find the domain of the function.**

3)  $g(x) = \frac{3x}{x^2 - 9}$

A)  $\{x \mid x > 9\}$

B)  $\{x \mid x \neq -3, 3\}$

C) all real numbers

D)  $\{x \mid x \neq 0\}$

3) \_\_\_\_\_

**For the function represented in the graph, determine the domain or range, as requested.**

4) Find the range.

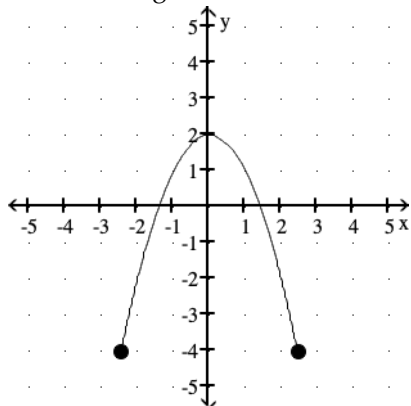

A)  $[-5, 5]$

B)  $[-2.45, 2.45]$

C)  $[-4, 2]$

D)  $[0, 0]$

4) \_\_\_\_\_

**Find the requested value.**

5)  $f(4)$  for  $f(x) = \begin{cases} 8x + 1, & \text{if } x < 1 \\ 4x, & \text{if } 4 \leq x \leq 6 \\ 4 - 2x, & \text{if } x > 6 \end{cases}$

A) 9

B) 16

C) -4

D) 13

5) \_\_\_\_\_

Use the graph of  $f$  to determine the intervals where  $f$  is increasing and where  $f$  is decreasing.

6)

6) \_\_\_\_\_

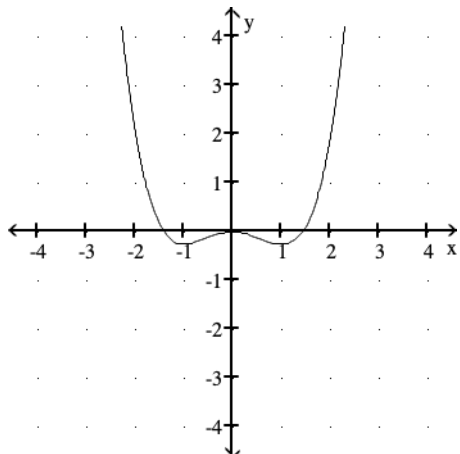

- A) increasing:  $[-1, 1]$ ; decreasing:  $(-\infty, -1] \cup [1, \infty)$
- B) increasing:  $[-1, 0] \cup [1, \infty)$ ; decreasing:  $(-\infty, -1] \cup [0, 1]$
- C) increasing:  $[0, \infty)$ ; decreasing:  $(-\infty, 0]$
- D) increasing:  $[-1, \infty)$ ; decreasing:  $(-\infty, -1]$

Locate relative maximum and relative minimum points on the graph. State whether each relative extremum point is a turning point.

7)

7) \_\_\_\_\_

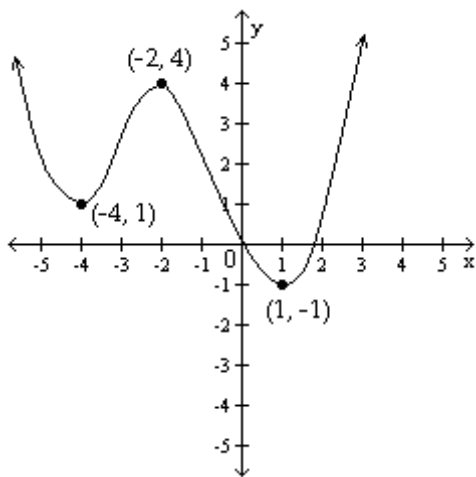

- A)  $(-2, 4)$  is a relative maximum point and a turning point.  $(-4, 1)$  and  $(1, -1)$  are relative minima points and turning points.
- B)  $(-2, 4)$  is a relative maximum.  $(-4, 1)$  and  $(1, -1)$  are relative minima points.
- C)  $(-2, 4)$  is a relative maximum and a turning point.  $(-4, 1)$  is a relative minimum point and a turning point.
- D)  $(-2, 4)$  is a relative maximum point and a turning point.  $(1, -1)$  is a relative minimum point and a turning point.

Evaluate.

8) Find  $(f - g)(2)$  when  $f(x) = -5x^2 + 3$  and  $g(x) = x - 5$ .

8) \_\_\_\_\_

- A) -24
- B) -10
- C) -14
- D) 15

9) Find  $\left(\frac{f}{g}\right)(-5)$  when  $f(x) = 2x - 7$  and  $g(x) = 2x^2 + 14x + 2$ .

9) \_\_\_\_\_

A)  $-\frac{1}{9}$

B)  $\frac{17}{18}$

C)  $\frac{2}{3}$

D)  $-\frac{1}{9}$

**For the pair of functions, find the indicated sum, difference, product, or quotient.**

10)  $f(x) = 6 - 2x$ ,  $g(x) = -8x^2 + 2$

10) \_\_\_\_\_

Find  $(f + g)(x)$ .

A)  $-10x^2 - 2x + 8$

B)  $-10x + 8$

C)  $-8x^2 - 2x + 8$

D)  $-8x^2 + 6$

**For the given functions f and g, find the indicated composition.**

11)  $f(x) = 4x^2 + 4x + 5$ ,  $g(x) = 4x - 6$

11) \_\_\_\_\_

$(g \circ f)(x)$

A)  $16x^2 + 16x + 14$

B)  $4x^2 + 4x - 1$

C)  $16x^2 + 16x + 26$

D)  $4x^2 + 16x + 14$

**Evaluate.**

12) Find  $(fg)(-2)$  when  $f(x) = x + 1$  and  $g(x) = 2x^2 + 20x - 7$ .

12) \_\_\_\_\_

A) 39

B) 43

C) 117

D) -3

**Find the requested function value.**

13) Find  $(f \circ g)(-2)$  when  $f(x) = 8x + 3$  and  $g(x) = -5x^2 + 5x + 1$ .

13) \_\_\_\_\_

A) 11

B) -229

C) 1

D) -909

**Find the requested value.**

14) Using the given tables, find  $(f \circ g)(4)$

14) \_\_\_\_\_

x	13	9	5	7
f(x)	26	18	10	14

x	6	4	7	5
g(x)	11	7	13	9

A) 7

B) 4

C) 18

D) 14

**Graph the function.**

15)  $g(x) = -(x + 5)^3 - 3$

15) \_\_\_\_\_

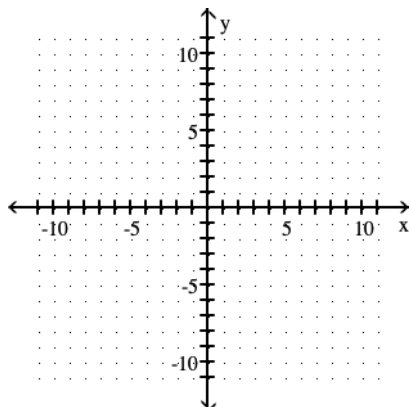

A)

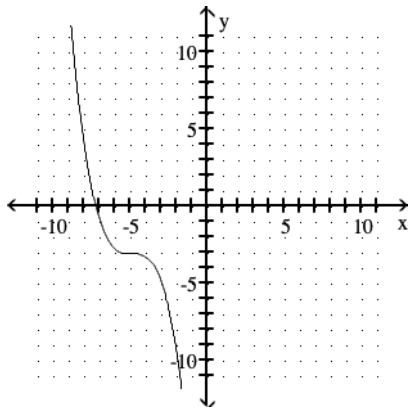

B)

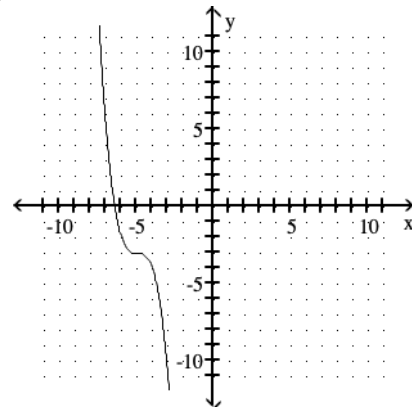

C)

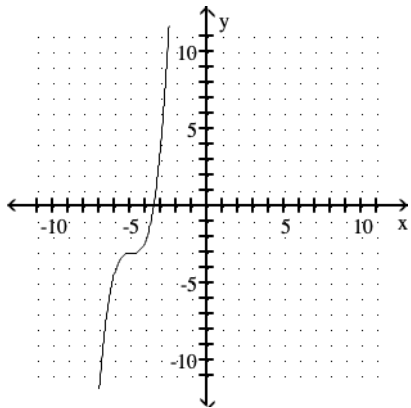

D)

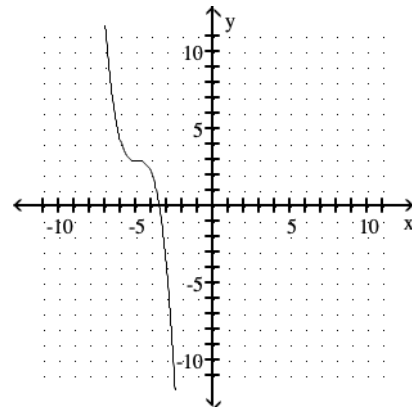

16)  $g(x) = \frac{1}{4}|x - 4| - 6$

16) \_\_\_\_\_

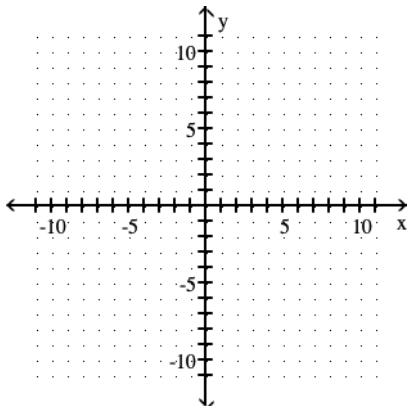

A)

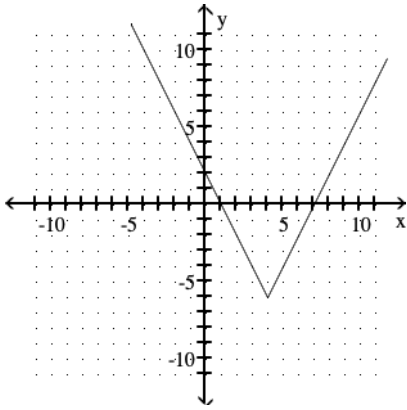

B)

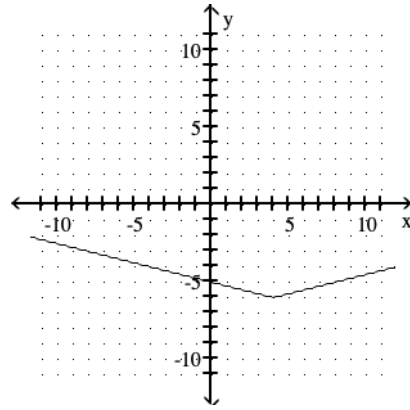

C)

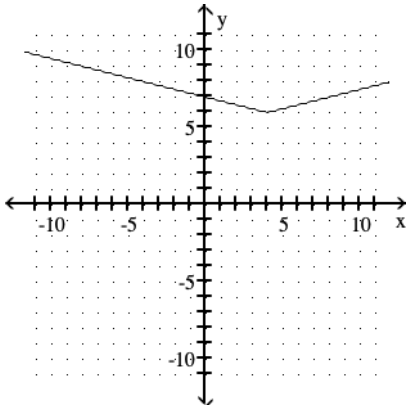

D)

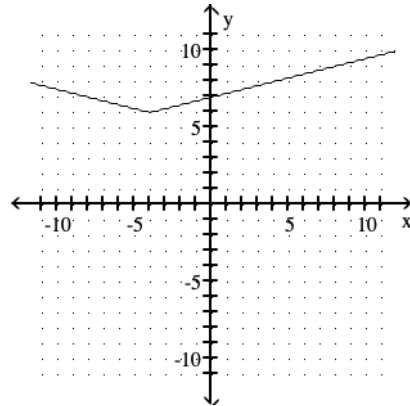

Does the graph represent a function that has an inverse function?

17)

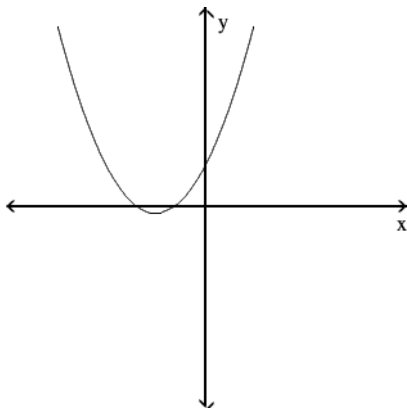

17) \_\_\_\_\_

A) Yes

B) No

Determine whether the given function is one-to-one. If it is one-to-one, find its inverse.

18)  $f(x) = \sqrt[3]{x-6}$

18) \_\_\_\_\_

A)  $f^{-1}(x) = (x+6)^3$

B)  $f^{-1}(x) = \sqrt[3]{x-6}$

C)  $f^{-1}(x) = x^3 + 6$

D)  $f^{-1}(x) = (x-6)^3$

If the function is one-to-one, find its inverse. If not, write "not one-to-one."

19)  $f(x) = \frac{5}{x-9}$

19) \_\_\_\_\_

A)  $f^{-1}(x) = \frac{-9+5x}{x}$

B) not a one-to-one

C)  $f^{-1}(x) = \frac{9x+5}{x}$

D)  $f^{-1}(x) = \frac{x}{-9+5x}$

Find an equation for the line with the given properties.

20) The solid line L contains the point (1, 4) and is perpendicular to the dotted line whose equation is  $y = 2x$ . Give the equation of line L in slope-intercept form.

20) \_\_\_\_\_

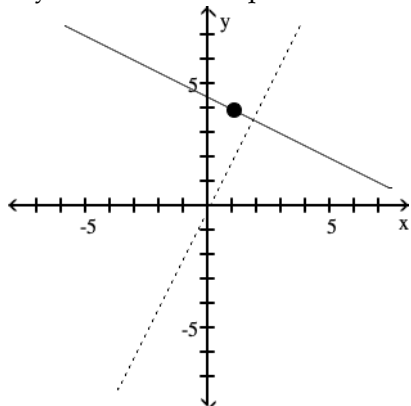

A)  $y = -\frac{1}{2}x + \frac{9}{2}$

B)  $y - 4 = -\frac{1}{2}(x - 1)$

C)  $y = \frac{1}{2}x + \frac{9}{2}$

D)  $y - 4 = 2(x - 1)$

Write an equation for the linear function and use it to answer the given question.

21) You can rent time on computers at the local copy center for a \$7 setup charge and an additional \$ 4 for every 5 minutes. How much time can you rent for \$17?

21) \_\_\_\_\_

A)  $r = 7 - 0.8t$ ; 30 minutes

B)  $r = 7t - 0.8$ ; 2.54 minutes

C)  $r = 7t + 0.8$ ; 2.31 minutes

D)  $r = 7 + 0.8t$ ; 12.5 minutes

Solve the problem.

22) Northwest Molded molds plastic handles which cost \$0.10 per handle to mold. The fixed cost to run the molding machine is \$8644 per week. If the company sells the handles for \$4.10 each, how many handles must be molded and sold weekly to break even?

22) \_\_\_\_\_

A) 2058 handles

B) 1440 handles

C) 86,440 handles

D) 2161 handles

Divide and express the result in standard form.

23)  $\frac{6-3i}{5+3i}$

23) \_\_\_\_\_

A)  $\frac{39}{34} - \frac{3}{34}i$

B)  $\frac{21}{34} - \frac{33}{34}i$

C)  $\frac{39}{16} - \frac{33}{16}i$

D)  $\frac{21}{16} - \frac{33}{16}i$

Solve the equation.

24)  $x^2 + 4x + 8 = 0$

- A)  $\{-2 - 4i, -2 + 4i\}$   
C)  $\{-2 - 2i, -2 + 2i\}$

- B)  $\{-2 - 2i\}$   
D)  $\{0, -4\}$

24) \_\_\_\_\_

Find the vertex and axis of symmetry of the graph of the function.

25)  $f(x) = x^2 + 4x - 5$

- A)  $(-2, 9); x = -2$   
C)  $(2, -9); x = 2$

- B)  $(2, 9); x = 2$   
D)  $(-2, -9); x = -2$

25) \_\_\_\_\_

Graph the function using its vertex, axis of symmetry, and intercepts.

26)  $f(x) = x^2 - 2x$

26) \_\_\_\_\_

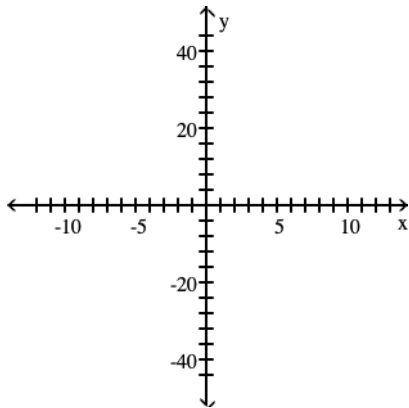

- A) vertex  $(1, -1)$   
intercepts  $(0, 0), (2, 0)$

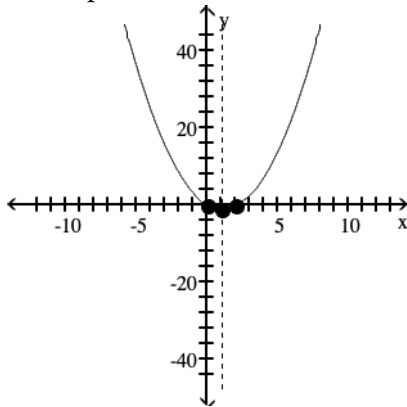

- B) vertex  $(1, 1)$   
intercept  $(0, 2)$

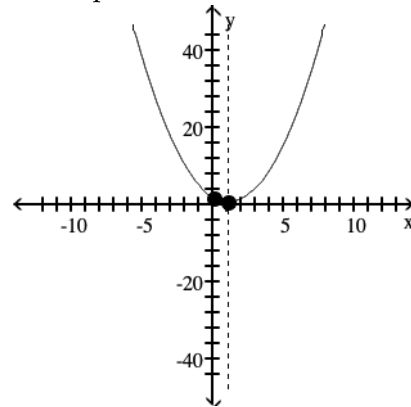

C) vertex  $(-1, 1)$   
intercept  $(0, 2)$

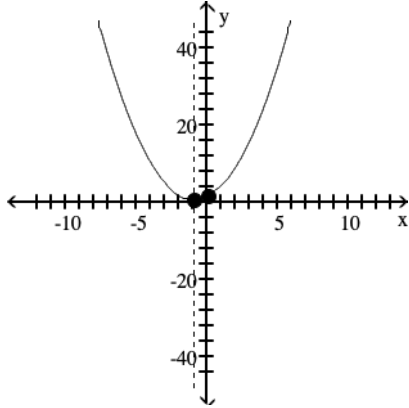

D) vertex  $(-1, -1)$   
intercepts  $(0, 0), (-2, 0)$

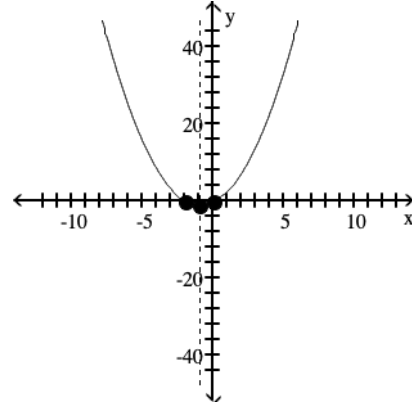

**Solve the problem.**

- 27) A rock is propelled upward from the top of a building 80 feet tall at an initial velocity of 136 feet per second. The function that describes the height of the rocket in terms of time  $t$  is  $s(t) = -16t^2 + 136t + 80$ . Determine the maximum height that the rock reaches. 27) \_\_\_\_\_
- A) 331 ft                      B) 387 ft                      C) 351 ft                      D) 369 ft

- 28) The owner of a video store has determined that the cost  $C$ , in dollars, of operating the store is approximately given by  $C(x) = 2x^2 - 22x + 760$ , where  $x$  is the number of videos rented daily. Find the lowest cost to the nearest dollar. 28) \_\_\_\_\_
- A) \$518                      B) \$639                      C) \$821                      D) \$700

**Determine whether the graph shown is the graph of a polynomial function.**

- 29) 29) \_\_\_\_\_

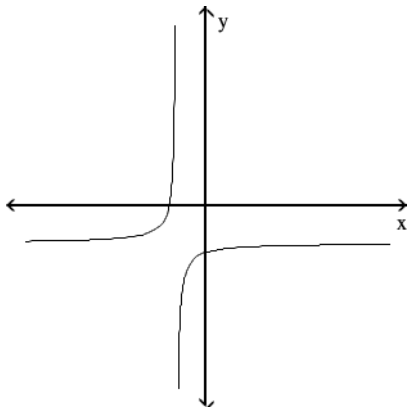

- A) polynomial function                      B) not a polynomial function



Use the Leading Coefficient Test to determine the end behavior of the polynomial function. Then use this end behavior to match the function with its graph.

30)  $f(x) = -6x^3 + 3x^2 + 3x + 1$

30) \_\_\_\_\_

A) rises to the left and rises to the right

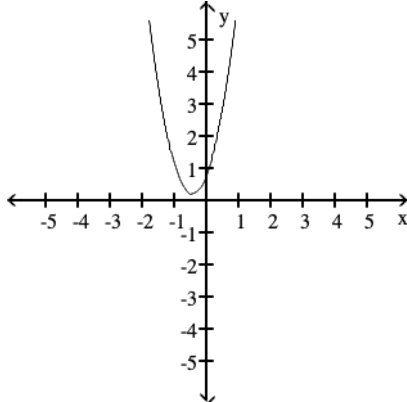

B) falls to the left and rises to the right

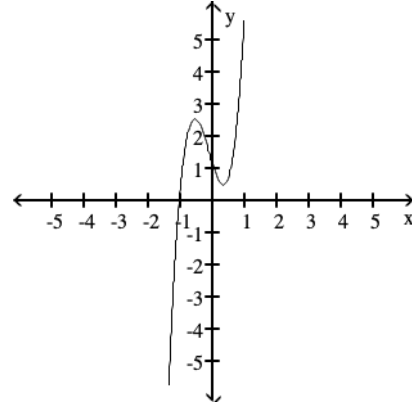

C) rises to the left and falls to the right

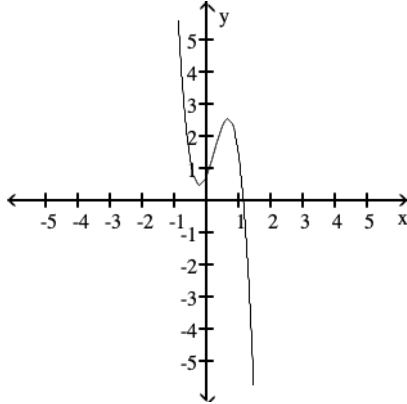

D) falls to the left and falls to the right

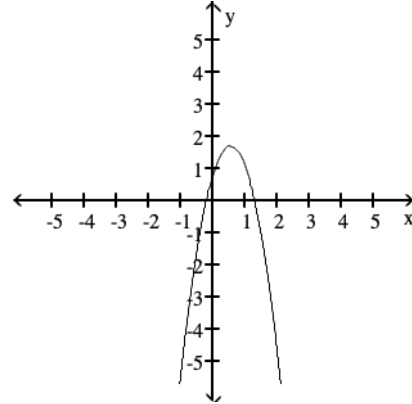

Divide using long division.

31)  $(-21x^2 + 64x - 35) \div (-7x + 5)$

31) \_\_\_\_\_

A)  $3x - 7$

B)  $x - 7$

C)  $-21x - 7$

D)  $-7x + 1$

Divide using synthetic division.

32)  $(x^2 + 15x + 49) \div (x + 6)$

32) \_\_\_\_\_

A)  $x + 10$

B)  $x + 9 - \frac{5}{x+6}$

C)  $\frac{x+9}{x+6}$

D)  $x + 9 + \frac{5}{x+6}$

Solve the problem.

33) Use synthetic division to divide  $f(x) = x^3 + 11x^2 + 16x - 84$  by  $x + 7$ . Use the result to find all zeros of  $f$ .

33) \_\_\_\_\_

A)  $\{-7, 6, -2\}$

B)  $\{7, -6, 2\}$

C)  $\{-7, -6, 2\}$

D)  $\{7, 6, -2\}$

Use the Rational Zero Test to list all possible rational zeros for the given function.

34)  $f(x) = -2x^3 + 4x^2 - 3x + 8$

34) \_\_\_\_\_

A)  $\pm \frac{1}{2}, \pm 1, \pm 2, \pm 4, \pm 8$

B)  $\pm \frac{1}{8}, \pm \frac{1}{4}, \pm \frac{1}{2}, \pm 1, \pm 2, \pm 4, \pm 8$

C)  $\pm \frac{1}{4}, \pm \frac{1}{2}, \pm 1, \pm 2, \pm 4, \pm 8$

D)  $\pm \frac{1}{2}, \pm 1, \pm 2, \pm 4$

Find the vertical asymptotes, if any, of the graph of the rational function.

35)  $h(x) = \frac{x + 5}{x^2 - 25}$

35) \_\_\_\_\_

A)  $x = 5, x = -5$

B)  $x = 5$

C)  $x = -5$

D) no vertical asymptote

Find the horizontal asymptote, if any, of the graph of the rational function.

36)  $g(x) = \frac{7x^2 - 3x - 6}{3x^2 - 8x + 6}$

36) \_\_\_\_\_

A)  $y = 0$

B)  $y = \frac{7}{3}$

C)  $y = \frac{3}{8}$

D) no horizontal asymptote

Graph the rational function.

37)  $f(x) = \frac{4x^2}{x^2 - 25}$

37) \_\_\_\_\_

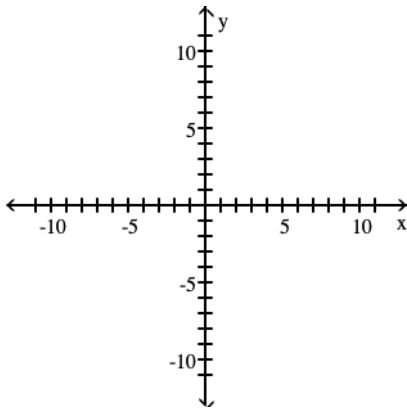

A)

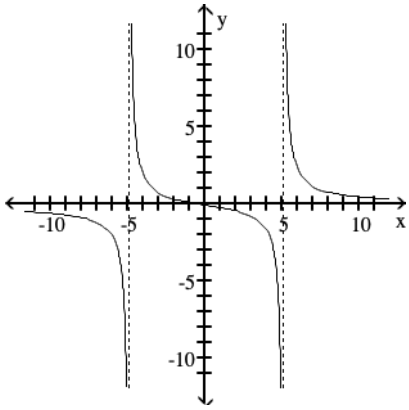

B)

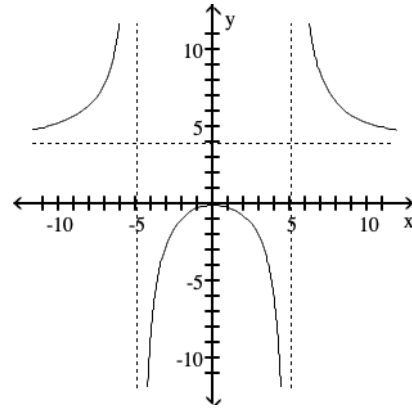

C)

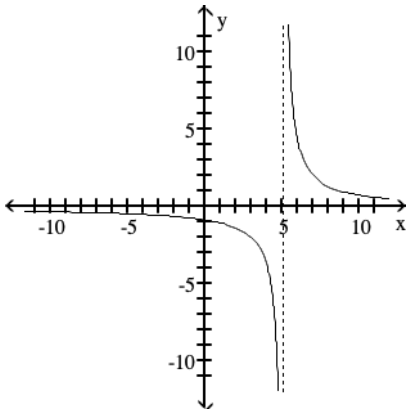

D)

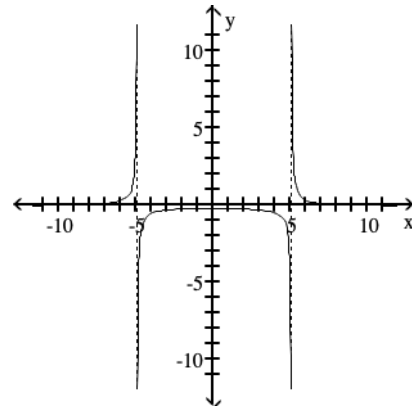

Graph the function.

$$38) f(x) = \frac{x^2 - 4}{x}$$

38) \_\_\_\_\_

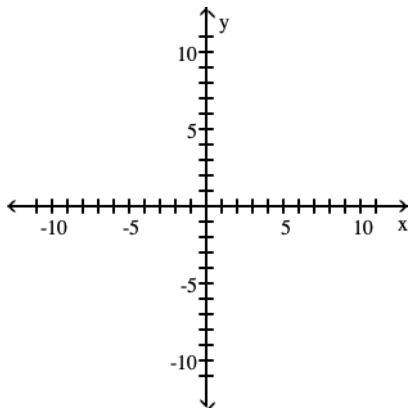

A)

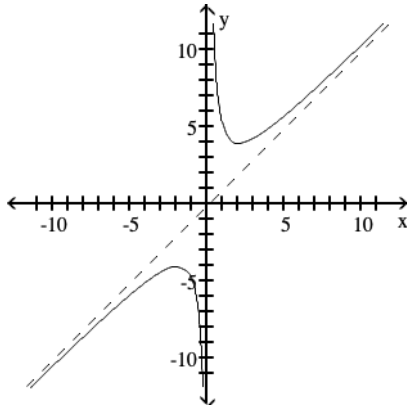

B)

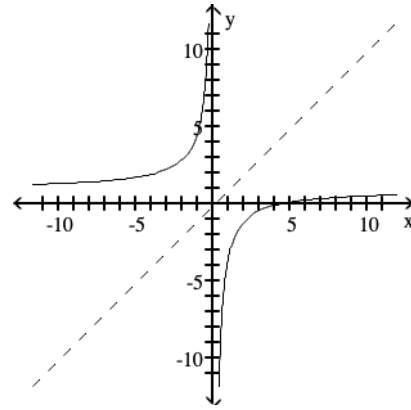

C)

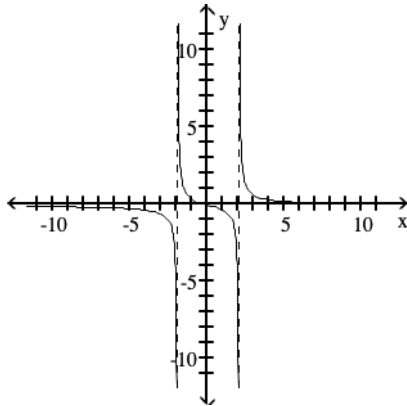

D)

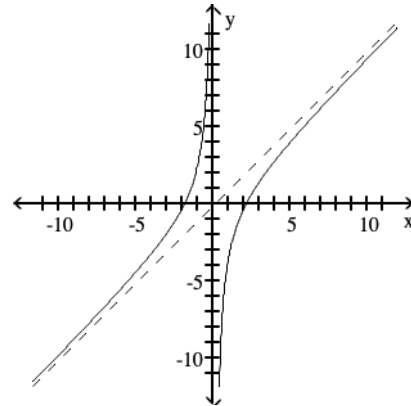

Solve the equation by expressing each side as a power of the same base and then equating exponents.

$$39) 9^x + 5 = 27^x - 3$$

A) {8}

B) {19}

C) {13}

D) {14}

39) \_\_\_\_\_

Solve the exponential equation. Use a calculator to obtain a decimal approximation, correct to two decimal places, for the solution.

$$40) 3^{(4x - 1)} = 19$$

A) {0.27}

B) {0.42}

C) {1.83}

D) {0.92}

40) \_\_\_\_\_

Use the compound interest formulas  $A = P\left(1 + \frac{r}{n}\right)^{nt}$  and  $A = Pe^{rt}$  to solve.

41) Find the accumulated value of an investment of \$1500 at 12% compounded quarterly for 2 years. 41) \_\_\_\_\_

A) \$1591.35

B) \$1881.60

C) \$1860.00

D) \$1900.16

42) Find the accumulated value of an investment of \$5000 at 5% compounded monthly for 8 years. 42) \_\_\_\_\_

A) \$12,911.25

B) \$8060.16

C) \$9093.60

D) \$7452.93

43) Find the accumulated value of an investment of \$5000 at 8% compounded continuously for 6 years. 43) \_\_\_\_\_

A) \$7400.00

B) \$8180.37

C) \$8080.37

D) \$7934.37

Solve the equation.

44)  $\log_6 (x^2 - x) = 1$  44) \_\_\_\_\_

- A)  $\{-2, 3\}$                       B)  $\{1, 6\}$                       C)  $\{2, 3\}$                       D)  $\{-2, -3\}$

Solve the logarithmic equation. Be sure to reject any value that is not in the domain of the original logarithmic expressions. Give the exact answer.

45)  $\log_2 (x + 2) + \log_2 (x - 4) = 4$  45) \_\_\_\_\_

- A)  $\{-4\}$                       B)  $\{7\}$                       C)  $\{6\}$                       D)  $\{6, -4\}$

46)  $\log_5 (x + 2) - \log_5 x = 2$  46) \_\_\_\_\_

- A)  $\{5\}$                       B)  $\{\frac{2}{25}\}$                       C)  $\{12\}$                       D)  $\{\frac{1}{12}\}$

Find a positive angle and a negative angle that are coterminal to the given angle.

47)  $43^\circ$  47) \_\_\_\_\_

- A)  $403^\circ; -137^\circ$                       B)  $133^\circ; -47^\circ$                       C)  $403^\circ; -317^\circ$                       D)  $223^\circ; -137^\circ$

Convert the angle from degree measure to radian measure. Round to the nearest hundredth of a radian when appropriate.

48)  $450^\circ$  48) \_\_\_\_\_

- A)  $-\frac{5\pi}{4}$                       B)  $\frac{5\pi}{2}$                       C)  $5\pi$                       D)  $-\frac{5\pi}{2}$

Convert the angle from radian measure to degree measure. Round to the nearest hundredth of a degree when appropriate.

49)  $\frac{7\pi}{4}$  49) \_\_\_\_\_

- A)  $315^\circ$                       B)  $102.86^\circ$                       C)  $154.29^\circ$                       D)  $630^\circ$

Solve the problem.

50) Use the formula  $s = r\theta$  to determine the value of  $s$  in the figure. Round to two decimal places, if necessary. 50) \_\_\_\_\_

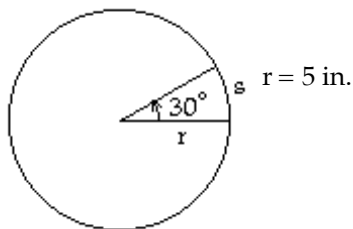

- A) 0.52 in.                      B) 9.55 in.                      C) 150 in.                      D) 2.62 in.

51) Find the area of the shaded sector. Round to one decimal place.

51) \_\_\_\_\_

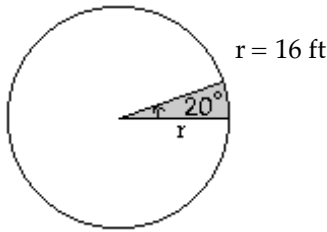

A)  $2.8 \text{ ft}^2$

B)  $89.4 \text{ ft}^2$

C)  $44.7 \text{ ft}^2$

D)  $0.5 \text{ ft}^2$

Use the given trigonometric function value of  $\theta$  to find the requested trigonometric function value of the acute angle  $\theta$ . Rationalize the denominator where necessary.

52)  $\cot \theta = \frac{\sqrt{3}}{3}$  Find  $\sin \theta$ .

52) \_\_\_\_\_

A)  $\sqrt{3}$

B)  $\frac{\sqrt{3}}{2}$

C)  $\frac{1}{2}$

D) 2

Rewrite the expression in terms of  $\sin \theta$  and  $\cos \theta$ .

53)  $\tan \theta(\cot \theta - \cos \theta)$

53) \_\_\_\_\_

A) 1

B)  $1 - \sin \theta$

C) 0

D)  $-\sec^2 \theta$

Use a calculator to find the approximate value of the expression. Round the answer to two decimal places.

54)  $\cos \frac{2\pi}{5}$

54) \_\_\_\_\_

A) 1.00

B) 1.07

C) 0.31

D) 0.38

Solve the problem.

55) Find the height of a pine tree that casts a 43-foot shadow on the ground assuming that the angle of elevation from the point on the ground at the tip of the shadow to the sun is  $64^\circ$ . Round your answer to the nearest foot.

55) \_\_\_\_\_

A) 88 ft

B) 21 ft

C) 39 ft

D) 19 ft

56) A conservation officer needs to know the width of a river in order to set instruments correctly for a study of pollutants in the river. From point A, the conservation officer walks 110 feet downstream and sights point B on the opposite bank to determine that  $\theta = 50^\circ$  (see figure). How wide is the river?

56) \_\_\_\_\_

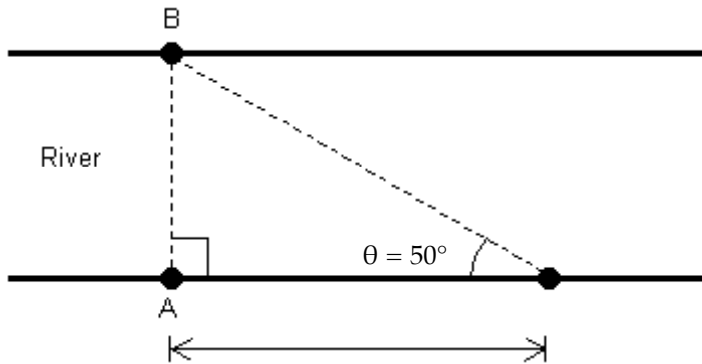

- A) 84 ft                      110 ft.                      B) 171 ft                      C) 92 ft                      D) 131 ft

**A point on the terminal side of angle  $\theta$  is given. Find the exact value of the indicated trigonometric function.**

57)  $(-2, -3)$  Find  $\sec \theta$ .

57) \_\_\_\_\_

- A)  $-\frac{\sqrt{13}}{2}$                       B)  $-\frac{2\sqrt{13}}{13}$                       C)  $\frac{\sqrt{13}}{3}$                       D)  $\frac{3}{2}$

**Name the quadrant in which the angle  $\theta$  lies.**

58)  $\cot \theta < 0, \cos \theta > 0$

58) \_\_\_\_\_

- A) I                      B) II                      C) III                      D) IV

**Find the reference angle of the given angle.**

59)  $406^\circ$

59) \_\_\_\_\_

- A)  $136^\circ$                       B)  $134^\circ$                       C)  $46^\circ$                       D)  $44^\circ$

**Find the exact value of the indicated trigonometric function of  $\theta$ .**

60)  $\sec \theta = \frac{9}{8}$ ,  $\theta$  in quadrant IV Find  $\tan \theta$ .

60) \_\_\_\_\_

- A)  $-\frac{\sqrt{17}}{8}$                       B)  $-\sqrt{17}$                       C)  $-\frac{\sqrt{17}}{9}$                       D)  $-\frac{9}{8}$

The figure shows angle  $\theta$  in standard position with its terminal side intersecting the unit circle. Evaluate  $\sin \theta$  and  $\cos \theta$ .

61)

61) \_\_\_\_\_

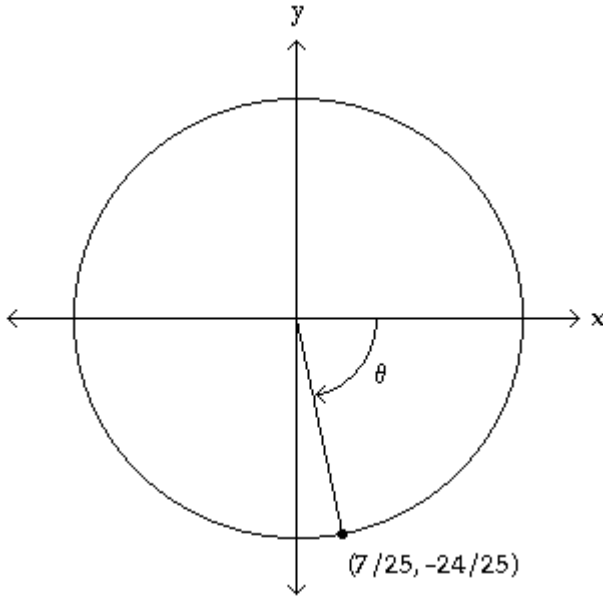

A)  $\sin \theta = -\frac{24}{7}, \cos \theta = -\frac{7}{24}$

B)  $\sin \theta = -\frac{25}{24}, \cos \theta = \frac{25}{7}$

C)  $\sin \theta = \frac{7}{25}, \cos \theta = -\frac{24}{25}$

D)  $\sin \theta = -\frac{24}{25}, \cos \theta = \frac{7}{25}$

Find the exact value of the expression.

62)  $\cos^{-1} \frac{\sqrt{3}}{2}$

62) \_\_\_\_\_

A)  $\frac{11\pi}{6}$

B)  $\frac{7\pi}{4}$

C)  $\frac{\pi}{6}$

D)  $\frac{\pi}{4}$

Use a calculator to find the value of the expression rounded to two decimal places.

63)  $\tan^{-1} (-2.2)$

63) \_\_\_\_\_

A) -65.56

B) -24.44

C) -0.43

D) -1.14

Express the given quantity in terms of  $\sin x$  or  $\cos x$ .

64)  $\sin (4\pi - x)$

64) \_\_\_\_\_

A)  $\sin (-x)$

B)  $-\sin x$

C)  $\cos x - \sin x$

D)  $\sin x$

65)  $\cos (4\pi + x)$

65) \_\_\_\_\_

A)  $-\cos x$

B)  $-\sin x$

C)  $\cos x$

D)  $\cos x - \sin x$



Use the given information to find the exact value.

66)  $\cos A = \frac{1}{3}$ ,  $0 < A < \frac{\pi}{2}$ ;  $\sin B = -\frac{1}{2}$ ,  $\frac{3\pi}{2} < B < 2\pi$  Find  $\sin(A - B)$ . 66) \_\_\_\_\_

A)  $\frac{\sqrt{3} - 2\sqrt{2}}{6}$       B)  $\frac{\sqrt{3} + 2\sqrt{2}}{6}$       C)  $\frac{2\sqrt{6} + 1}{6}$       D)  $\frac{2\sqrt{6} - 1}{6}$

Use the information given about the angle  $\theta$ , to find the exact value of the indicated trigonometric function.

67)  $\sin \theta = -\frac{4}{5}$ ,  $\theta$  in quadrant IV Find  $\sin 2\theta$ . 67) \_\_\_\_\_

A)  $-\frac{7}{25}$       B)  $\frac{24}{25}$       C)  $-\frac{24}{25}$       D)  $\frac{7}{25}$

Find the exact value by using a half-angle identity.

68)  $\cos 22.5^\circ$  68) \_\_\_\_\_

A)  $\frac{1}{2} \sqrt{2 - \sqrt{2}}$       B)  $-\frac{1}{2} \sqrt{2 + \sqrt{2}}$       C)  $-\frac{1}{2} \sqrt{2 - \sqrt{2}}$       D)  $\frac{1}{2} \sqrt{2 + \sqrt{2}}$

Which answer choice is equivalent to the given expression?

69)  $\cos x \tan x \csc x$  69) \_\_\_\_\_

A) 1      B)  $\cot x$       C)  $\sin x$       D) 2

Use the fundamental identities and simplify the expression to get a numerical value.

70)  $\cos x (\csc x - \sec x) - \cot x$  70) \_\_\_\_\_

A) 1      B) -1      C) 0      D)  $\cos^2 x - \tan^2 x$

71)  $\sin^2 x (\cot^2 x + 1)$  71) \_\_\_\_\_

A)  $\tan^2 x$       B) 1      C)  $\cos^2 x + 1$       D) -1

Which answer choice is equivalent to the given expression?

72)  $\sin 2x \csc x$  72) \_\_\_\_\_

A)  $2 \cot x$       B)  $2 \tan x$       C)  $2 \cos x$       D)  $2 \sec x$

73)  $\frac{1 + \tan^2 x}{\tan^2 x}$  73) \_\_\_\_\_

A)  $\sin^2 x$       B)  $\sec^2 x$       C)  $\csc^2 x$       D)  $\cos^2 x$

74)  $\cos^2 x - \sin^2 x$  74) \_\_\_\_\_

A)  $3 \tan^2 x$       B)  $\csc^2 x$       C)  $2 \cos^2 x - 1$       D) 1

Sketch the graph on the coordinate system provided.

75)  $y = -\sin 8x$

75) \_\_\_\_\_

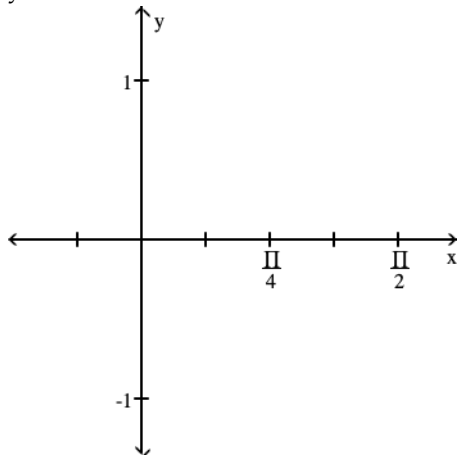

A)

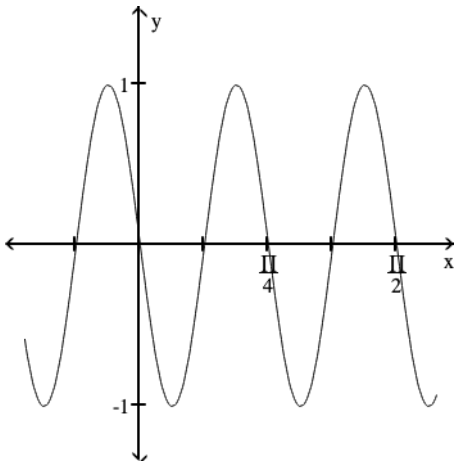

B)

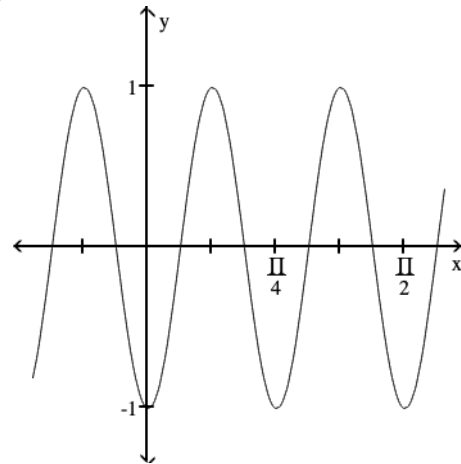

C)

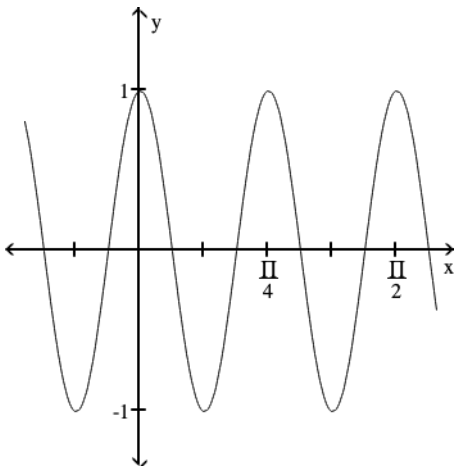

D)

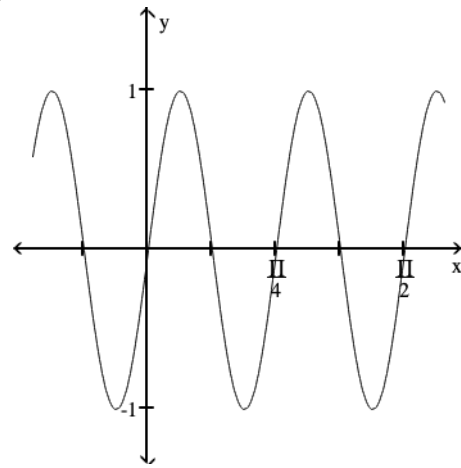

State the period of the function and graph.

76)  $\sin 4x$

76) \_\_\_\_\_

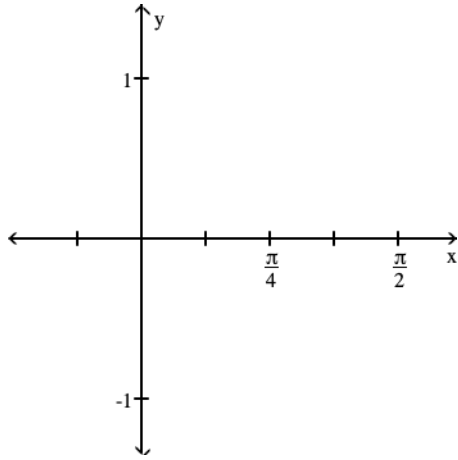

A) Period  $\frac{\pi}{2}$

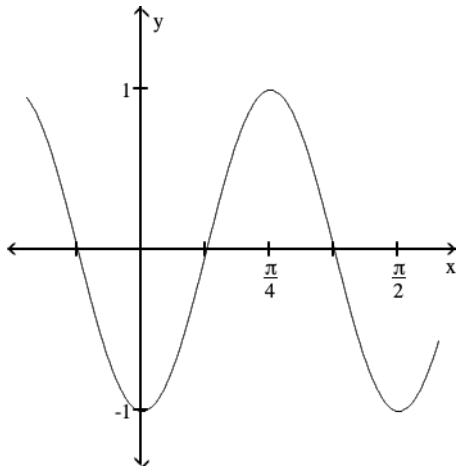

B) Period  $\frac{\pi}{2}$

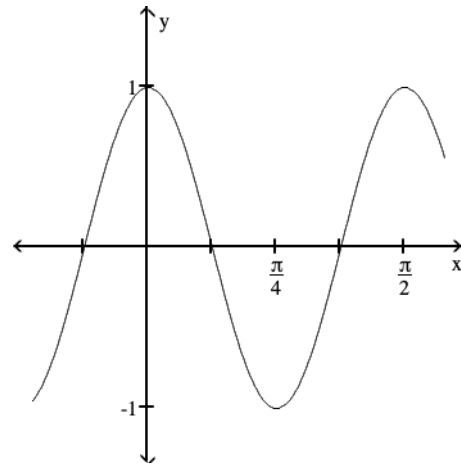

C) Period  $\frac{\pi}{2}$

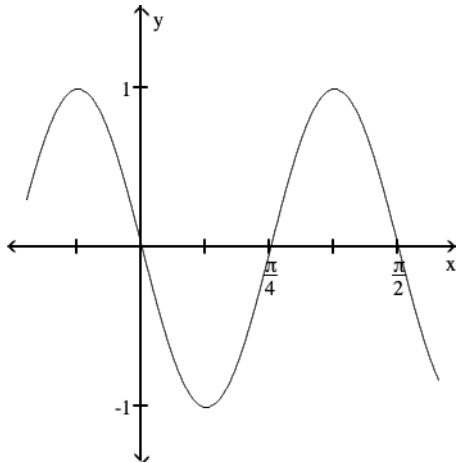

D) Period  $\frac{\pi}{2}$

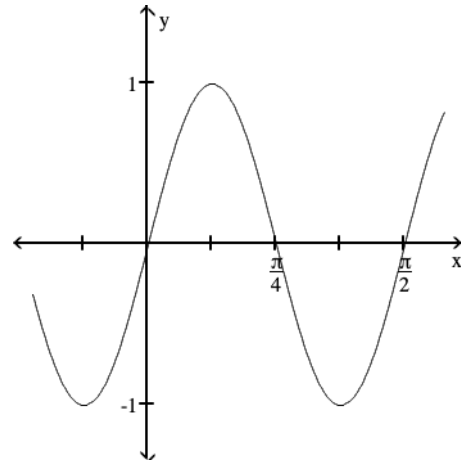

77)  $\cos 8x$

77) \_\_\_\_\_

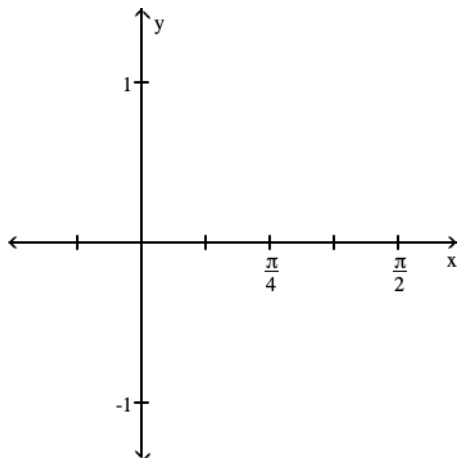

A) Period  $\frac{\pi}{4}$

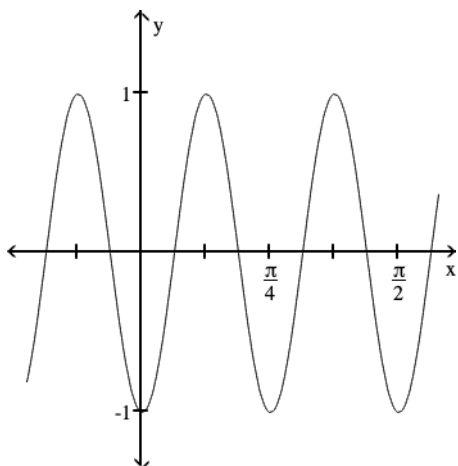

B) Period  $\frac{\pi}{4}$

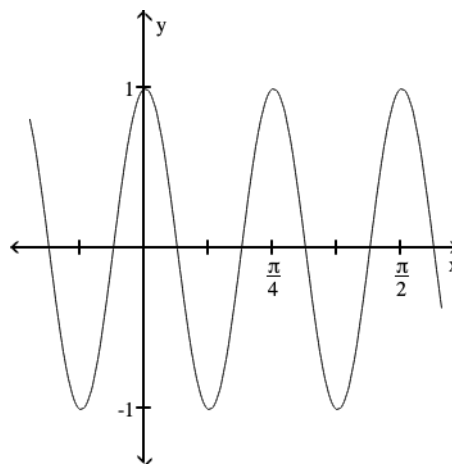

C) Period  $\frac{\pi}{4}$

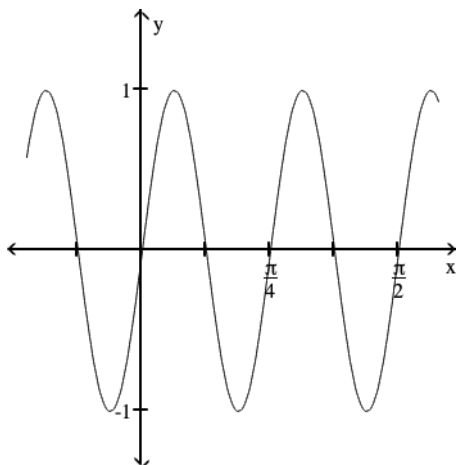

D) Period  $\frac{\pi}{4}$

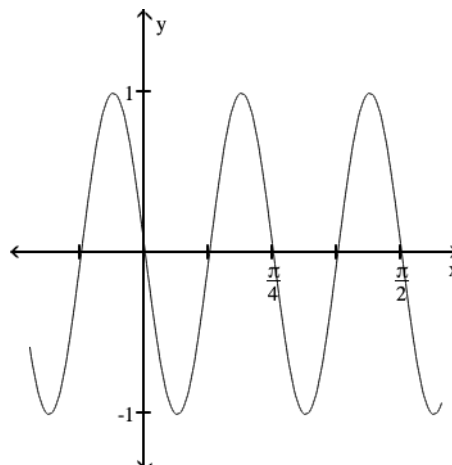

78)  $\sin\left(\frac{\pi x}{3}\right)$

78) \_\_\_\_\_

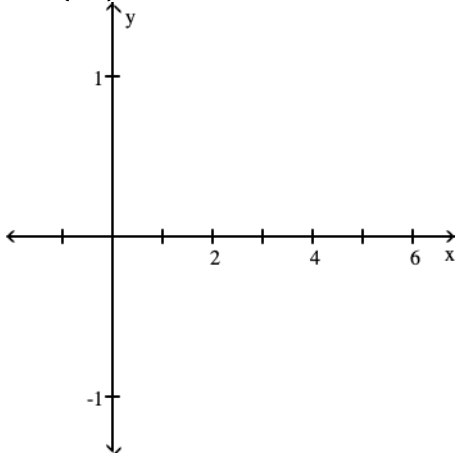

A) Period 6

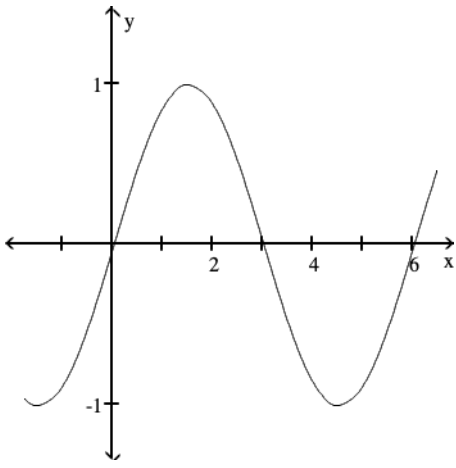

B) Period 6

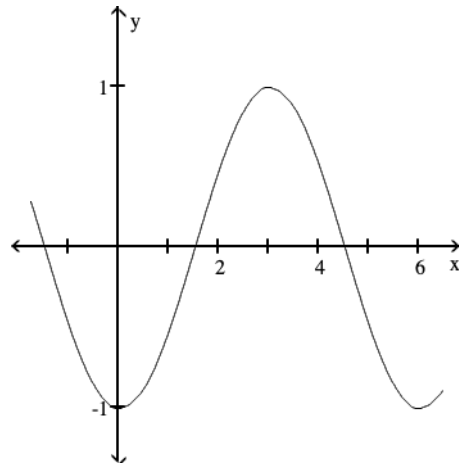

C) Period 6

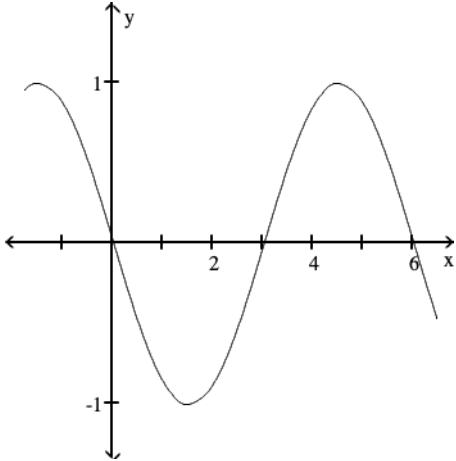

D) Period 6

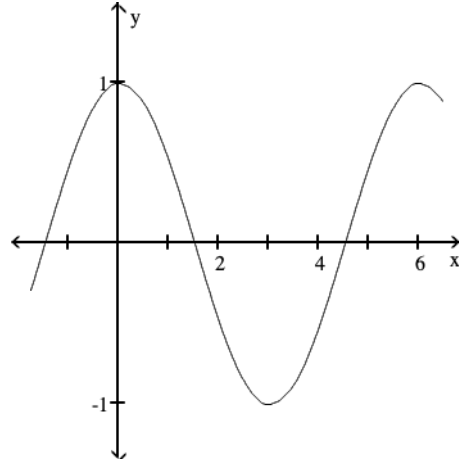

Graph the function.

79)  $y = 4 \sin(2x)$

79) \_\_\_\_\_

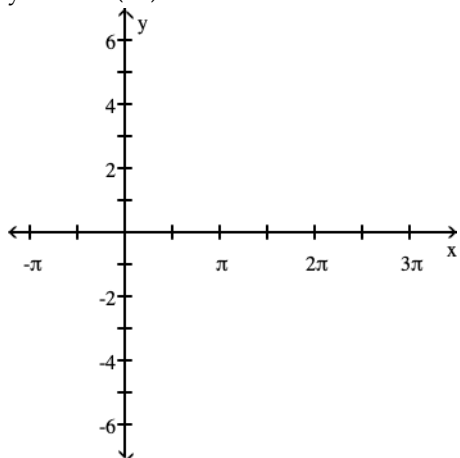

A)

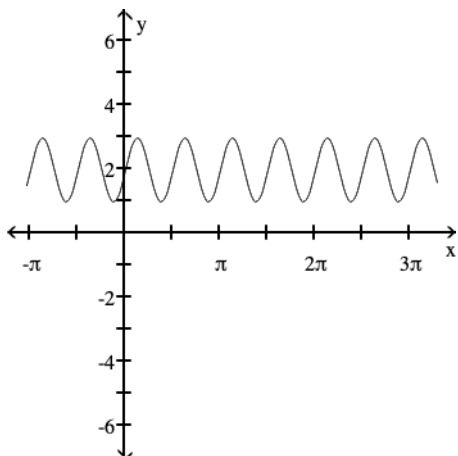

B)

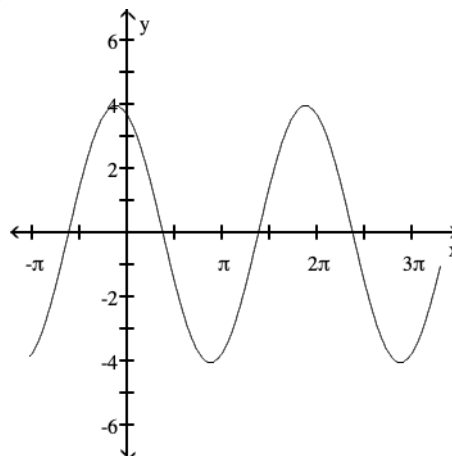

C)

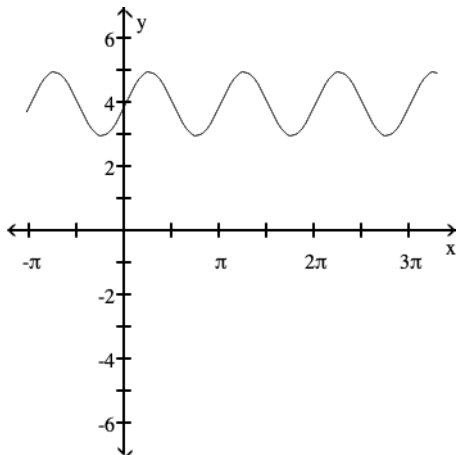

D)

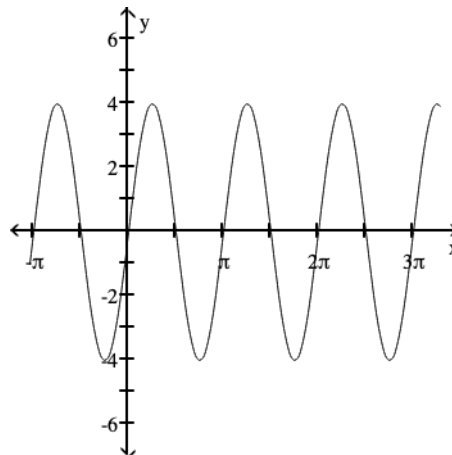

Compute the Amplitud, the Period and sketch the graph of the given equation over a period.

80)  $y = 4 \cos x$

80) \_\_\_\_\_

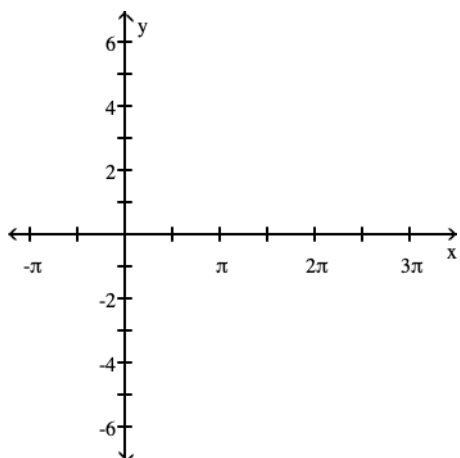

A)

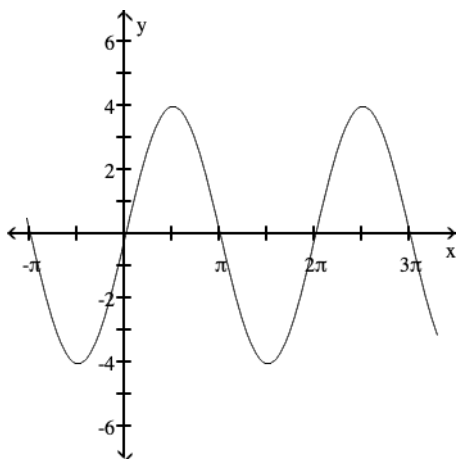

B)

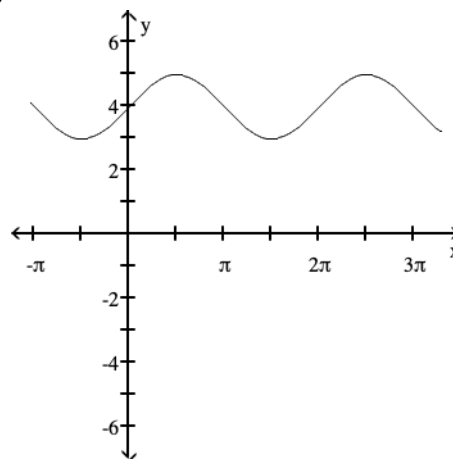

C)

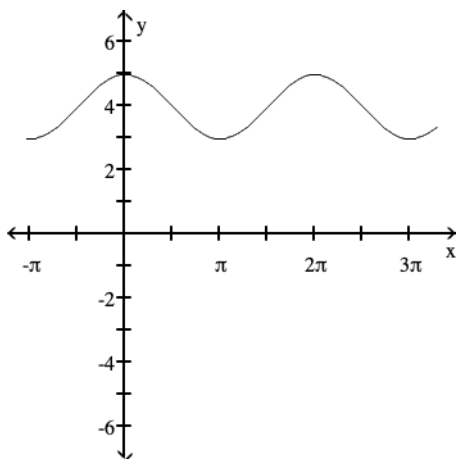

D)

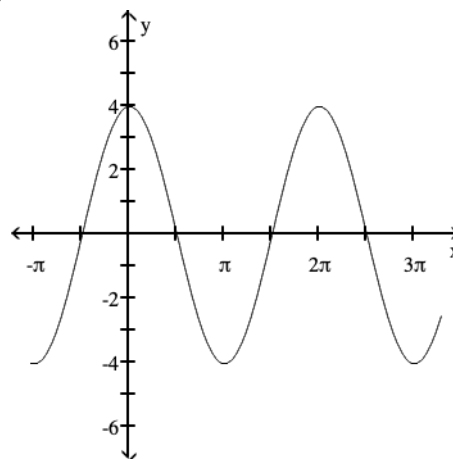

Compute the Amplitud, the Period and sketch the graph of the given equation over a period.

81)  $y = \frac{1}{2} \sin 2x$

81) \_\_\_\_\_

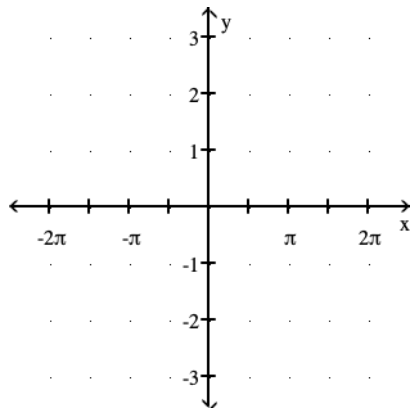

A)

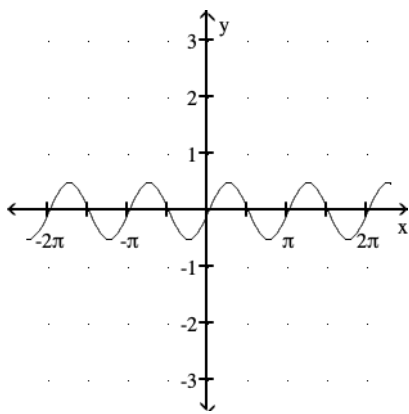

B)

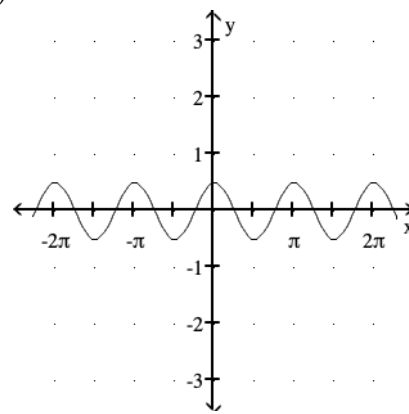

C)

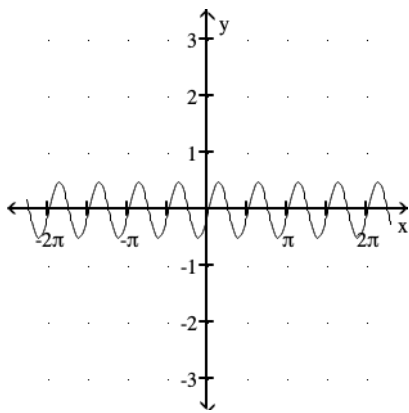

D)

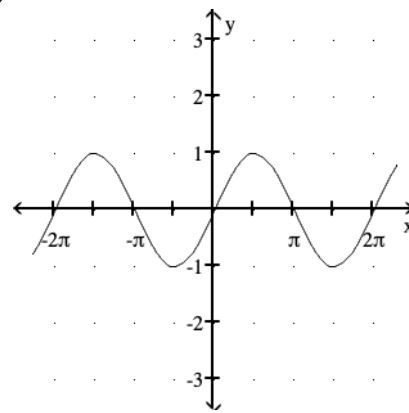

Graph the function in the ts-plane (t-axis horizontal, s-axis vertical). State the period and symmetry of the function.



82)  $s = -\tan 2t$

82) \_\_\_\_\_

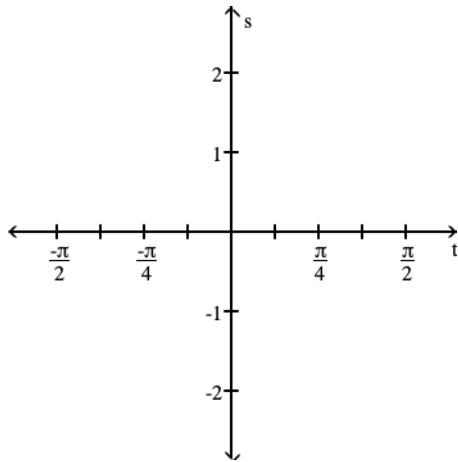

A) Period  $\frac{\pi}{2}$ , symmetric about the origin

B) Period  $\frac{\pi}{2}$ , symmetric about the s-axis

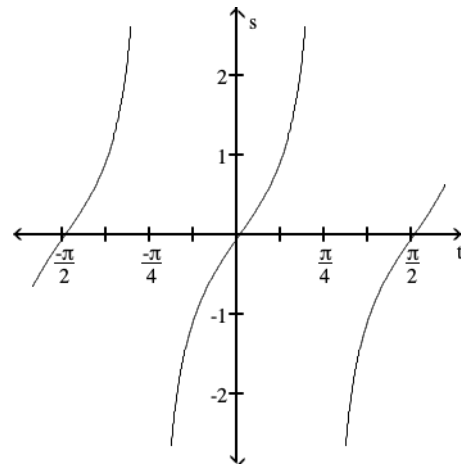
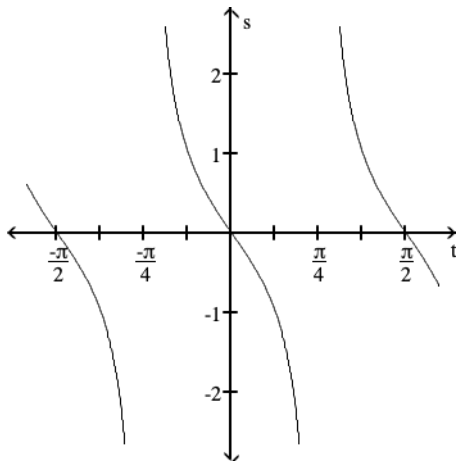

C) Period  $\frac{\pi}{2}$ , symmetric about the origin

D) Period  $\pi$ , symmetric about the origin

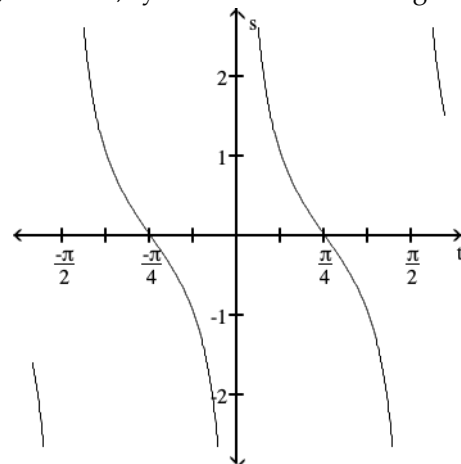
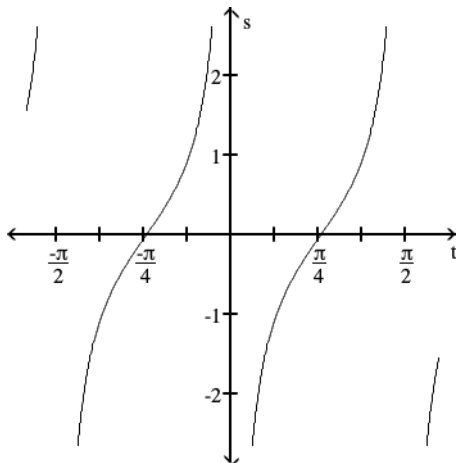

Use the product-to-sum identities to rewrite the expression as the sum or difference of two functions.

83)  $\cos 2\theta \cos 6\theta$

A)  $\frac{1}{2} \cos 8\theta - \frac{1}{2} \cos 4\theta$

B)  $\frac{1}{2} \cos 8\theta - \frac{1}{2} \sin 4\theta$

C)  $\cos^2 8\theta^2$

D)  $\frac{1}{2} \cos 4\theta + \frac{1}{2} \cos 8\theta$

83) \_\_\_\_\_

84)  $\sin 3\theta \sin 5\theta$

A)  $-\frac{1}{2} \cos 2\theta - \frac{1}{2} \cos 8\theta$

B)  $\frac{1}{2} \cos 8\theta - \frac{1}{2} \sin 2\theta$

C)  $\frac{1}{2} \cos 2\theta - \frac{1}{2} \cos 8\theta$

D)  $\sin^2 15\theta^2$

84) \_\_\_\_\_

Use sum-to-product identities to rewrite the expression as a product.

85)  $\sin \frac{\pi}{11} - \sin \frac{\pi}{2}$

A)  $2 \sin \frac{13\pi}{44} \cos \frac{9\pi}{44}$

B)  $-2 \sin \frac{9\pi}{44} \sin \frac{13\pi}{44}$

C)  $2 \cos \frac{9\pi}{44} \cos \frac{13\pi}{44}$

D)  $-2 \cos \frac{13\pi}{44} \sin \frac{9\pi}{44}$

85) \_\_\_\_\_

86)  $\cos 4x + \cos 2x$

A)  $2 \cos 3x$

B)  $2 \cos 3x \sin x$

C)  $2 \cos 3x \cos x$

D)  $2 \sin 3x \sin x$

86) \_\_\_\_\_

87)  $\sin 8x + \sin 2x$

A)  $2 \sin 5x \sin 3x$

B)  $2 \cos 5x \sin 3x$

C)  $2 \sin 5x \cos 3x$

D)  $2 \sin 10x$

87) \_\_\_\_\_

Solve the equation on the interval  $0 \leq \theta < 2\pi$ .

88)  $\cos \theta - 1 = 0$

A) 0

B)  $\frac{3\pi}{2}$

C)  $\frac{\pi}{2}$

D)  $\pi$

88) \_\_\_\_\_

89)  $5 \csc \theta - 1 = 4$

A)  $\frac{\pi}{2}$

B)  $\pi$

C)  $\frac{3\pi}{2}$

D)  $2\pi$

89) \_\_\_\_\_

90)  $2 \cos \theta + 1 = 0$

A)  $\frac{2\pi}{3}, \frac{4\pi}{3}$

B)  $\frac{\pi}{2}, \frac{3\pi}{2}$

C)  $\frac{\pi}{3}, \frac{5\pi}{3}$

D)  $\frac{3\pi}{2}$

90) \_\_\_\_\_

Solve the equation. Give a general formula for all the solutions.

91)  $\cos \theta - 1 = 0$

A)  $\theta = \frac{\pi}{2} + 2k\pi$

B)  $\theta = 2k\pi$

C)  $\theta = \frac{3\pi}{2} + 2k\pi$

D)  $\theta = \pi + 2k\pi$

91) \_\_\_\_\_

92)  $\sin \theta = 1$  92) \_\_\_\_\_  
 A)  $\theta = 0 + 2k\pi$       B)  $\theta = \pi + 2k\pi$       C)  $\theta = \frac{\pi}{2} + 2k\pi$       D)  $\theta = \frac{3\pi}{2} + 2k\pi$

93)  $\sin \theta = \frac{\sqrt{3}}{2}$  93) \_\_\_\_\_  
 A)  $\theta = \frac{\pi}{6} + k\pi, \theta = \frac{5\pi}{6} + k\pi$       B)  $\theta = \frac{\pi}{6} + 2k\pi, \theta = \frac{5\pi}{6} + 2k\pi$   
 C)  $\theta = \frac{\pi}{3} + k\pi, \theta = \frac{2\pi}{3} + k\pi$       D)  $\theta = \frac{\pi}{3} + 2k\pi, \theta = \frac{2\pi}{3} + 2k\pi$

94)  $2 \cos \theta + 1 = 0$  94) \_\_\_\_\_  
 A)  $\theta = \frac{3\pi}{2} + k\pi$       B)  $\theta = \frac{2\pi}{3} + k\pi, \theta = \frac{4\pi}{3} + k\pi$   
 C)  $\theta = \frac{2\pi}{3} + 2k\pi, \theta = \frac{4\pi}{3} + 2k\pi$       D)  $\theta = \frac{\pi}{2} + 2k\pi, \theta = \frac{3\pi}{2} + 2k\pi$

**Solve for the angle  $\theta$ , where  $0 \leq \theta \leq 2\pi$**

95)  $\sin^2 \theta = \frac{1}{4}$  95) \_\_\_\_\_  
 A)  $\theta = 0, \pi, 2\pi$       B)  $\theta = \frac{\pi}{6}, \frac{5\pi}{6}, \frac{7\pi}{6}, \frac{11\pi}{6}$   
 C)  $\theta = \frac{\pi}{3}, \frac{2\pi}{3}, \frac{4\pi}{3}, \frac{5\pi}{3}$       D)  $\theta = \frac{\pi}{4}, \frac{3\pi}{4}, \frac{5\pi}{4}, \frac{7\pi}{4}$

96)  $\cos^2 \theta = \frac{1}{4}$  96) \_\_\_\_\_  
 A)  $\theta = 0, \pi, 2\pi$       B)  $\theta = \frac{\pi}{3}, \frac{2\pi}{3}, \frac{4\pi}{3}, \frac{5\pi}{3}$   
 C)  $\theta = \frac{\pi}{4}, \frac{3\pi}{4}, \frac{5\pi}{4}, \frac{7\pi}{4}$       D)  $\theta = \frac{\pi}{6}, \frac{5\pi}{6}, \frac{7\pi}{6}, \frac{11\pi}{6}$

## Answer Key

Testname: REVIEW FOR FINAL EXAM

- 1) B
- 2) D
- 3) B
- 4) C
- 5) B
- 6) B
- 7) A
- 8) C
- 9) B
- 10) C
- 11) A
- 12) A
- 13) B
- 14) D
- 15) B
- 16) B
- 17) B
- 18) C
- 19) C
- 20) A
- 21) D
- 22) D
- 23) B
- 24) C
- 25) D
- 26) A
- 27) D
- 28) D
- 29) B
- 30) C
- 31) A
- 32) B
- 33) C
- 34) A
- 35) B
- 36) B
- 37) B
- 38) D
- 39) B
- 40) D
- 41) D
- 42) D
- 43) C
- 44) A
- 45) C
- 46) D
- 47) C
- 48) B
- 49) A

Answer Key

Testname: REVIEW FOR FINAL EXAM

- 50) D
- 51) C
- 52) B
- 53) B
- 54) C
- 55) A
- 56) D
- 57) A
- 58) D
- 59) C
- 60) A
- 61) D
- 62) C
- 63) D
- 64) B
- 65) C
- 66) C
- 67) C
- 68) D
- 69) A
- 70) B
- 71) B
- 72) C
- 73) C
- 74) C
- 75) A
- 76) D
- 77) B
- 78) A
- 79) D
- 80) D
- 81) A
- 82) A
- 83) D
- 84) C
- 85) D
- 86) C
- 87) C
- 88) A
- 89) A
- 90) A
- 91) B
- 92) C
- 93) D
- 94) C
- 95) B
- 96) B