

Review for Exam 2

MULTIPLE CHOICE. Choose the one alternative that best completes the statement or answers the question.

Express the number in terms of i.

1) $\sqrt{-81}$ A) $-9i$ B) $9i$ C) $\sqrt{9}i$ D) $-\sqrt{9}i$ 1) _____

2) $\sqrt{-45}$ A) $15i$ B) $-3\sqrt{5}i$ C) $5\sqrt{3}i$ D) $3\sqrt{5}i$ 2) _____

Add or subtract as indicated and write the result in standard form.

3) $(8 - 3i) + (3 + 5i)$ A) $11 + 2i$ B) $5 + 8i$ C) $11 - 2i$ D) $-11 - 2i$ 3) _____

4) $(3 + 4i) - (-8 + i)$ A) $11 + 3i$ B) $-11 - 3i$ C) $11 - 3i$ D) $-5 + 5i$ 4) _____

5) $3i + (-7 - i)$ A) $7 - 2i$ B) $-7 + 4i$ C) $7 - 4i$ D) $-7 + 2i$ 5) _____

Find the product and write the result in standard form.

6) $(3 - 2i)(-2 - 6i)$ A) $-18 - 22i$ B) $-18 - 14i$ C) $6 - 22i$ D) $6 - 14i$ 6) _____

7) $(4 - 8i)^2$ A) -48 B) $80 - 64i$ C) $16 - 64i + 64i^2$ D) $-48 - 64i$ 7) _____

Divide and express the result in standard form.

8) $\frac{3 - 4i}{4 + 3i}$ A) i B) 1 C) $-i$ D) -1 8) _____

9) $\frac{3 - 4i}{7 + 4i}$ A) $\frac{1}{13} - \frac{8}{13}i$ B) $\frac{37}{13} + \frac{16}{13}i$ C) $\frac{37}{33} - \frac{8}{33}i$ D) $\frac{1}{33} - \frac{8}{33}i$ 9) _____

10) $\frac{5i}{7 - 2i}$ A) $-\frac{10}{53} + \frac{35}{53}i$ B) $-\frac{2}{9} - \frac{7}{9}i$ C) $\frac{7}{9} - \frac{2}{9}i$ D) $\frac{35}{53} - \frac{10}{53}i$ 10) _____

Solve the equation.

11) $x^2 + 100 = 0$ A) $\{10i\}$ B) $\{10\}$ C) $\{-10, 10\}$ D) $\{-10i, 10i\}$ 11) _____

12) $x^2 + 12x + 45 = 0$

A) $\{-3, -9\}$

C) $\{-6 - 9i, -6 + 9i\}$

B) $\{-6 - 3i\}$

D) $\{-6 - 3i, -6 + 3i\}$

12) _____

13) $x^2 - 12x + 40 = 0$

A) $\{6 + 2i, 6 - 2i\}$

B) $\{6 + 2i\}$

C) $\{8, 4\}$

D) $\{6 - 4i, 6 + 4i\}$

13) _____

Find the vertex and axis of symmetry of the graph of the function.

14) $f(x) = x^2 + 6x + 8$

A) $(-3, -1); x = -3$

B) $(-3, 1); x = -3$

C) $(3, -1); x = 3$

D) $(3, 1); x = 3$

14) _____

Graph the function using its vertex, axis of symmetry, and intercepts.

15) $f(x) = x^2 + 4x$

15) _____

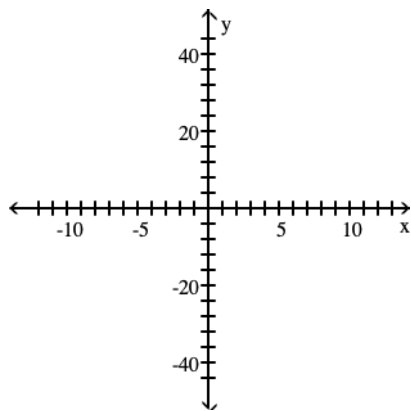

A) vertex $(-2, 4)$
intercept $(0, 8)$

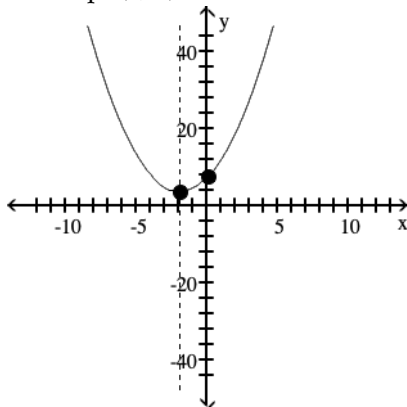

B) vertex $(-2, -4)$
intercepts $(0, 0), (-4, 0)$

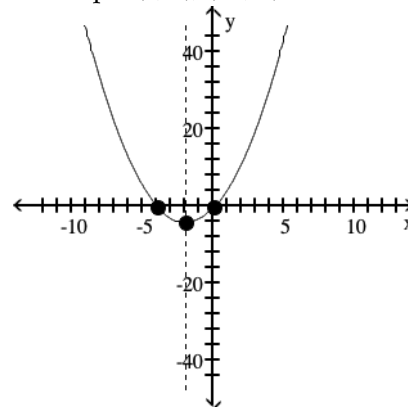

C) vertex (2, -4)
intercepts (0, 0), (4, 0)

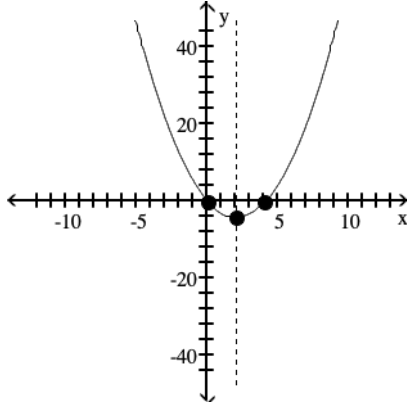

D) vertex (2, 4)
intercept (0, 8)

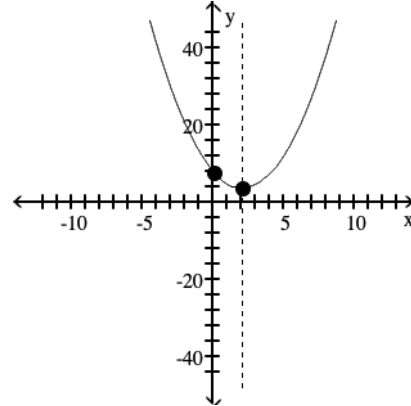

Determine whether there is a maximum or minimum value for the given function, and find that value.

16) $f(x) = x^2 + 4x - 3$ 16) _____
 A) Maximum: 7 B) Minimum: 0 C) Minimum: -7 D) Maximum: -7

17) $f(x) = -x^2 - 6x - 15$ 17) _____
 A) Maximum: -6 B) Maximum: 6 C) Minimum: 6 D) Minimum: 0

Solve the problem.

18) A rock is propelled upward from the top of a building 150 feet tall at an initial velocity of 72 feet per second. The function that describes the height of the rocket in terms of time t is $s(t) = -16t^2 + 72t + 150$. Determine the maximum height that the rock reaches. 18) _____
 A) 250 ft B) 231 ft C) 262 ft D) 212 ft

19) The owner of a video store has determined that the cost C , in dollars, of operating the store is approximately given by $C(x) = 2x^2 - 26x + 700$, where x is the number of videos rented daily. Find the lowest cost to the nearest dollar. 19) _____
 A) \$362 B) \$785 C) \$616 D) \$531

20) The owner of a video store has determined that the profits P of the store are approximately given by $P(x) = -x^2 + 90x + 71$, where x is the number of videos rented daily. Find the maximum profit to the nearest dollar. 20) _____
 A) \$4121 B) \$4050 C) \$2025 D) \$2096

21) The manufacturer of a CD player has found that the revenue R (in dollars) is $R(p) = -4p^2 + 1370p$, when the unit price is p dollars. If the manufacturer sets the price p to maximize revenue, what is the maximum revenue to the nearest whole dollar? 21) _____
 A) \$469,225 B) \$938,450 C) \$117,306 D) \$234,613

Determine whether the graph shown is the graph of a polynomial function.

22)

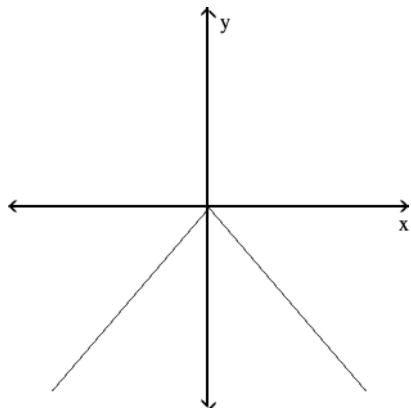

A) not a polynomial function

B) polynomial function

22) _____

23)

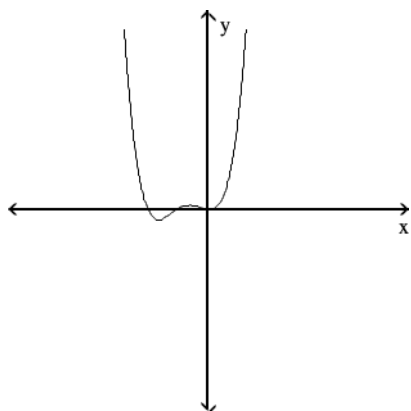

A) not a polynomial function

B) polynomial function

23) _____

24)

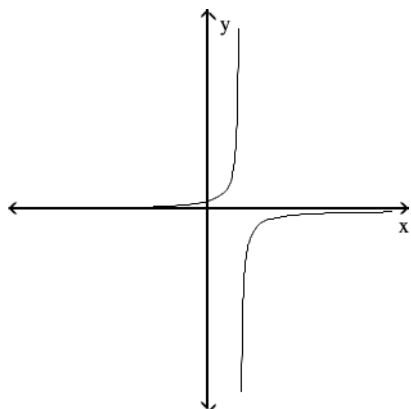

A) polynomial function

B) not a polynomial function

24) _____

Use the Leading Coefficient Test to determine the end behavior of the polynomial function. Then use this end behavior to match the function with its graph.

25) $f(x) = -8x^3 + 2x^2 + 4x + 1$

25) _____

A) falls to the left and falls to the right

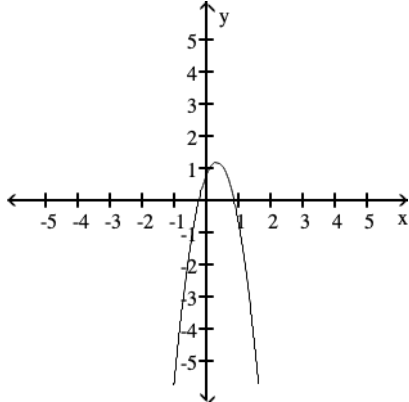

B) rises to the left and rises to the right

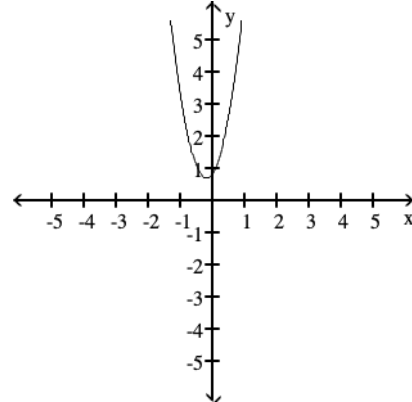

C) rises to the left and falls to the right

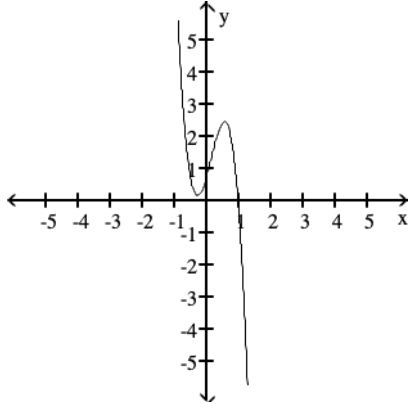

D) falls to the left and rises to the right

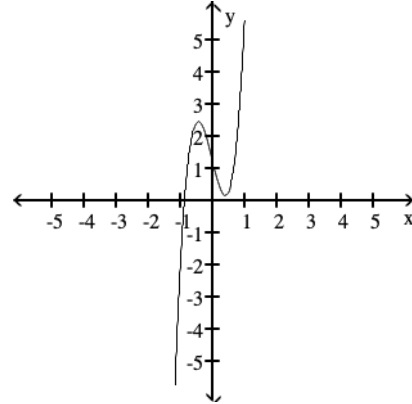

Use the Leading Coefficient Test to determine the end behavior of the polynomial function.

26) $f(x) = 2x^4 - 2x^3 + 5x^2 - 3x + 1$

26) _____

A) rises to the left and falls to the right

B) rises to the left and rises to the right

C) falls to the left and falls to the right

D) falls to the left and rises to the right

27) $f(x) = -5x^4 - 5x^3 - 3x^2 - 4x - 3$

27) _____

A) falls to the left and rises to the right

B) rises to the left and falls to the right

C) rises to the left and rises to the right

D) falls to the left and falls to the right

28) $f(x) = -2x^3 - 2x^2 - 2x + 2$

28) _____

A) rises to the left and rises to the right

B) falls to the left and rises to the right

C) falls to the left and falls to the right

D) rises to the left and falls to the right

Use the Leading Coefficient Test to determine the end behavior of the polynomial function. Then use this end behavior to match the function with its graph.

29) $f(x) = 2x^4 - 3x^2$

29) _____

A) falls to the left and rises to the right

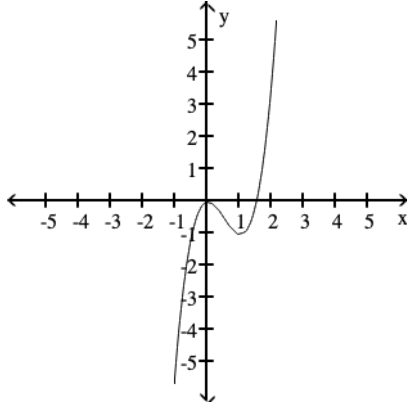

B) rises to the left and rises to the right

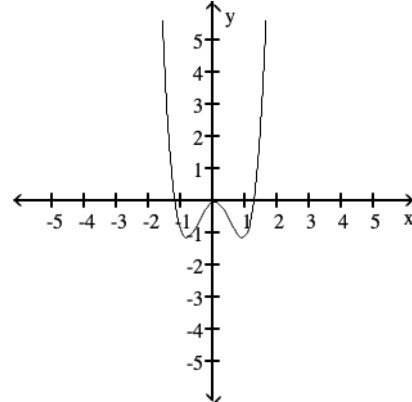

C) rises to the left and falls to the right

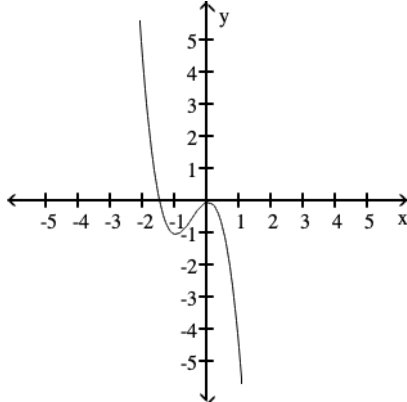

D) falls to the left and falls to the right

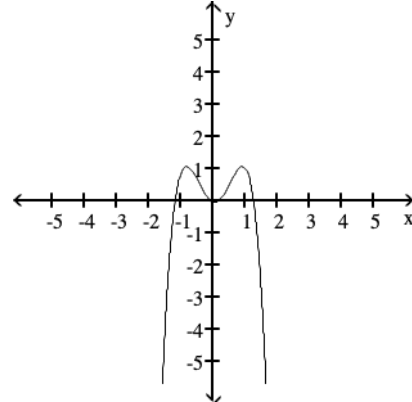

Find the zeros of the polynomial function.

30) $f(x) = x^3 + x^2 - 12x$

30) _____

A) $x = 0, x = -4, x = 3$

B) $x = -4, x = 3$

C) $x = 2, x = 3$

D) $x = 0, x = 2, x = 3$

31) $f(x) = x^3 + 5x^2 - 4x - 20$

31) _____

A) $x = 5, x = -2, x = 2$

B) $x = -5, x = -2, x = 2$

C) $x = -5, x = 4$

D) $x = -2, x = 2$

Divide using long division.

32) $(35x^2 - 46x + 15) \div (-7x + 5)$

32) _____

A) $x + 3$

B) $-5x + 3$

C) $35x + 3$

D) $3x + 1$

Divide using synthetic division.

33) $\frac{5x^2 + 42x + 16}{x + 8}$

33) _____

A) $2x + 8$

B) $x + 2$

C) $5x + 2$

D) $-5x - 2$

34) $(x^2 + 9x + 5) \div (x + 2)$ 34) _____
 A) $x + 7 + \frac{9}{x + 2}$ B) $\frac{x + 7}{x + 2}$ C) $x + 7 - \frac{9}{x + 2}$ D) $x + 8$

35) $(x^2 + 15x + 56) \div (x + 7)$ 35) _____
 A) $x^2 + 8$ B) $x + 8$ C) $x^3 - 49$ D) $x - 49$

36) $(x^2 + 7x + 8) \div (x + 2)$ 36) _____
 A) $x + 5 - \frac{2}{x + 2}$ B) $x + 5 + \frac{2}{x + 2}$ C) $x + 6$ D) $\frac{x + 5}{x + 2}$

Use the remainder theorem and synthetic division to find f(k).

37) $k = 3$; $f(x) = x^3 - 5x^2 + 3x + 3$ 37) _____
 A) -63 B) -6 C) -60 D) -12

Solve the problem.

38) Use synthetic division to divide $f(x) = x^3 + 15x^2 + 68x + 96$ by $x + 8$. Use the result to find all zeros of f. 38) _____
 A) {8, -4, -3} B) {8, 4, 3} C) {-8, -4, -3} D) {-8, 4, 3}

39) Use synthetic division to divide $f(x) = x^3 + 5x^2 - 17x - 21$ by $x + 7$. Use the result to find all zeros of f. 39) _____
 A) {-7, -3, 1} B) {7, -3, 1} C) {7, 3, -1} D) {-7, 3, -1}

Use synthetic division to show that the number given to the right of the equation is a solution of the equation, then solve the polynomial equation.

40) $x^3 - 5x^2 + 2x + 8 = 0$; 4 40) _____
 A) {-2, 1, 4} B) {2, -1, 4} C) {2, 1, 4} D) {-2, -1, 4}

41) $3x^3 - 5x^2 - 16x + 12 = 0$; 3 41) _____
 A) $\left\{-\frac{2}{3}, 2, 3\right\}$ B) $\left\{\frac{2}{3}, -2, 3\right\}$ C) $\left\{\frac{2}{3}, 2, 3\right\}$ D) $\left\{-\frac{2}{3}, -2, 3\right\}$

Use the Rational Zero Test to list all possible rational zeros for the given function.

42) $f(x) = x^5 - 2x^2 + 4x + 15$ 42) _____
 A) $\pm 1, \pm 5, \pm 3$ B) $\pm 1, \pm \frac{1}{5}, \pm \frac{1}{3}, \pm \frac{1}{15}$
 C) $\pm 1, \pm 5, \pm 3, \pm 15$ D) $\pm 1, \pm \frac{1}{5}, \pm \frac{1}{3}, \pm \frac{1}{15}, \pm 5, \pm 3, \pm 15$

- 43) $f(x) = x^4 + 5x^3 - 6x^2 + 5x - 12$ 43) _____
 A) $\pm 1, \pm 2, \pm 3, \pm 4, \pm 6, \pm 12$
 B) $\pm 1, \pm \frac{1}{2}, \pm \frac{1}{3}, \pm \frac{1}{4}, \pm \frac{1}{6}, \pm \frac{1}{12}$
 C) $\pm \frac{1}{12}, \pm 1, \pm 12$
 D) $\pm \frac{1}{2}, \pm \frac{1}{3}, \pm \frac{1}{4}, \pm \frac{1}{6}, \pm \frac{1}{12}, \pm 1, \pm 2, \pm 3, \pm 4, \pm 6, \pm 12$

- 44) $f(x) = -2x^3 + 4x^2 - 3x + 8$ 44) _____
 A) $\pm \frac{1}{2}, \pm 1, \pm 2, \pm 4$ B) $\pm \frac{1}{2}, \pm 1, \pm 2, \pm 4, \pm 8$
 C) $\pm \frac{1}{4}, \pm \frac{1}{2}, \pm 1, \pm 2, \pm 4, \pm 8$ D) $\pm \frac{1}{8}, \pm \frac{1}{4}, \pm \frac{1}{2}, \pm 1, \pm 2, \pm 4, \pm 8$

Given the polynomial function $f(x)$, find the rational zeros, then the other zeros (that is, solve the equation $f(x) = 0$), and factor $f(x)$ into linear factors.

- 45) $f(x) = x^3 - 48x - 128$ 45) _____
 A) -4, multiplicity 2; 8; $f(x) = (x + 4)^2(x - 8)$
 B) -8, -4, 4; $f(x) = (x + 8)(x + 4)(x - 4)$
 C) -4, multiplicity 2; -8; $f(x) = (x + 4)^2(x + 8)$
 D) -4, 4, 8; $f(x) = (x + 4)(x - 4)(x - 8)$
- 46) $f(x) = x^3 - 27x - 54$ 46) _____
 A) -3, multiplicity 2; 6; $f(x) = (x + 3)^2(x - 6)$
 B) -3, multiplicity 2; -6; $f(x) = (x + 3)^2(x + 6)$
 C) -6, -3, 3; $f(x) = (x + 6)(x + 3)(x - 3)$
 D) -3, 3, 6; $f(x) = (x + 3)(x - 3)(x - 6)$
- 47) $f(x) = x^3 + 3x^2 + 25x + 75$ 47) _____
 A) -3, 75i, 25i; $f(x) = (x + 3)(x - 75i)(x - 25i)$
 B) -3, $-\sqrt{5}$, multiplicity 2; $f(x) = (x + 3)(x + \sqrt{5})^2$
 C) -3, -5i, 5i; $f(x) = (x + 3)(x + 5i)(x - 5i)$
 D) $-\sqrt{3}$, multiplicity 2; 5i; $f(x) = (x + \sqrt{3})^2(x - 5i)$

Use the graph of the rational function shown to complete the statement.

48)

48) _____

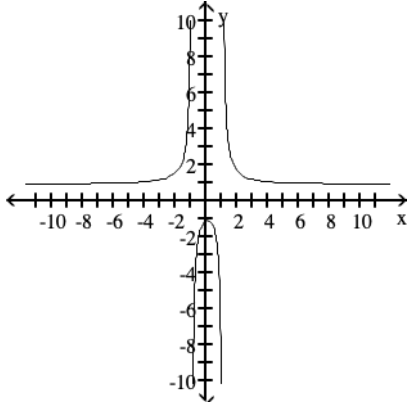

As $x \rightarrow 1^-$, $f(x) \rightarrow ?$

A) -1

B) $+\infty$

C) 1

D) $-\infty$

Find the vertical asymptotes, if any, of the graph of the rational function.

49) $f(x) = \frac{x}{x - 5}$

49) _____

A) $x = 5$

B) $x = 0$ and $x = -5$

C) $x = 0$ and $x = 5$

D) no vertical asymptote

50) $h(x) = \frac{x + 6}{x^2 - 36}$

50) _____

A) $x = 6, x = -6$

B) $x = -6$

C) $x = 6$

D) no vertical asymptote

51) $\frac{x - 36}{x^2 - 11x + 24}$

51) _____

A) $x = -36$

B) $x = 8, x = 3$

C) $x = -8, x = -3$

D) $x = 8, x = 3, x = -36$

Find the horizontal asymptote, if any, of the graph of the rational function.

52) $f(x) = \frac{8x}{2x^2 + 1}$

52) _____

A) $y = \frac{1}{4}$

B) $y = 0$

C) $y = 4$

D) no horizontal asymptote

$$53) g(x) = \frac{4x^2 - 7x - 9}{8x^2 - 6x + 8}$$

53) _____

A) $y = 0$

B) $y = \frac{7}{6}$

C) $y = \frac{1}{2}$

D) no horizontal asymptote

$$54) h(x) = \frac{12x^3}{3x^2 + 1}$$

54) _____

A) $y = 4$

B) $y = \frac{1}{4}$

C) $y = 0$

D) no horizontal asymptote

Graph the rational function.

$$55) f(x) = \frac{4x}{x^2 - 1}$$

55) _____

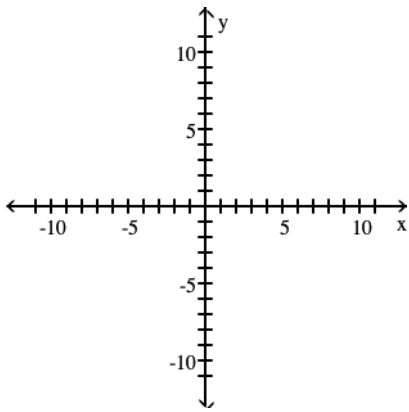

A)

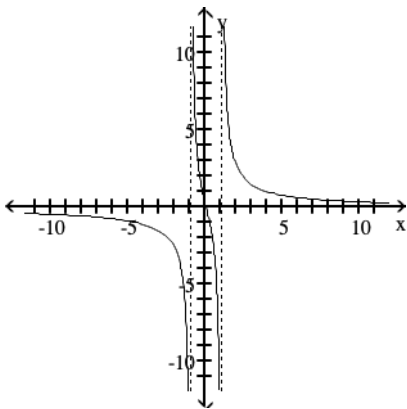

B)

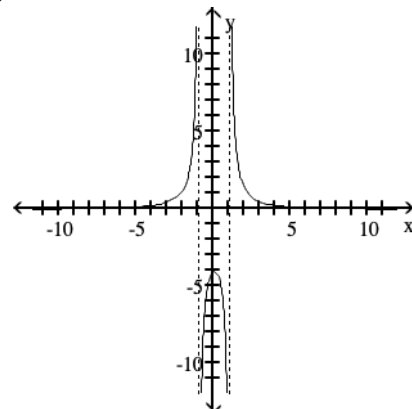

C)

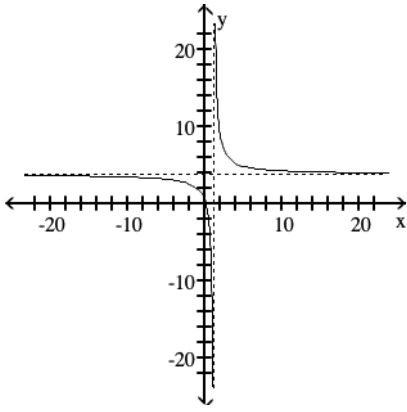

D)

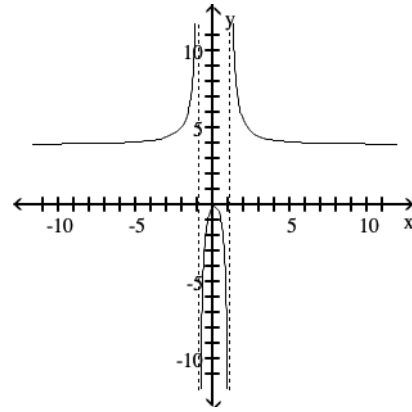

56) $f(x) = \frac{2x^2}{x^2 - 4}$

56) _____

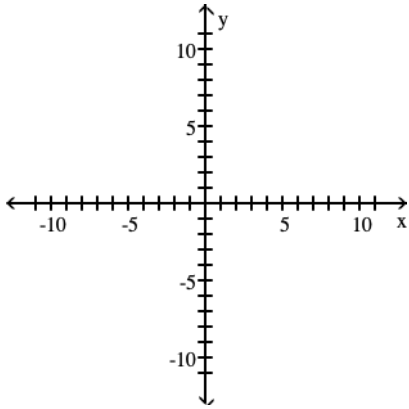

A)

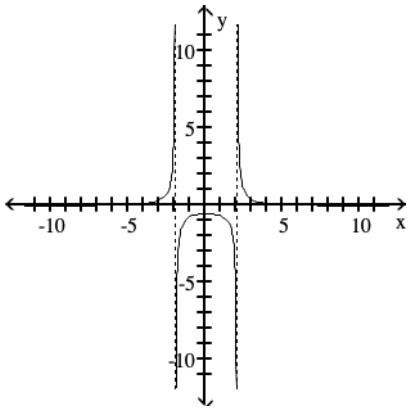

B)

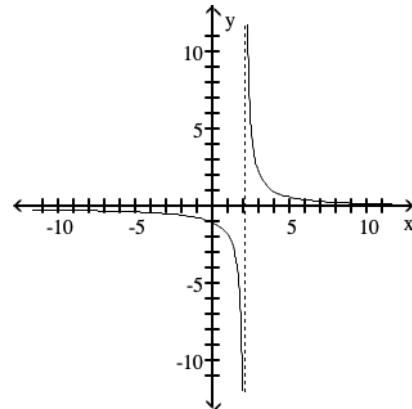

C)

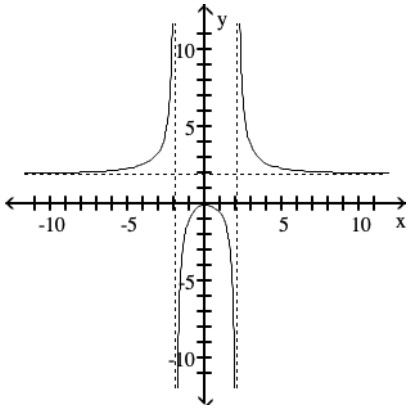

D)

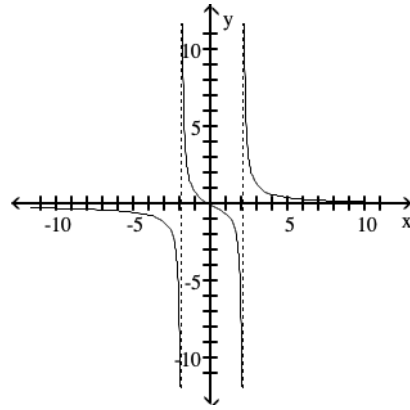

Find the slant asymptote, if any, of the graph of the rational function.

57) $f(x) = \frac{x^2 + 3x - 7}{x - 9}$

57) _____

- A) $y = x$
- C) $y = x + 12$

- B) $y = x + 3$
- D) no slant asymptote

58) $f(x) = \frac{x^2 - 4x + 2}{x + 6}$

58) _____

- A) $y = x - 10$
- C) $x = y + 4$

- B) $y = x + 6$
- D) no slant asymptote

Graph the function.

59) $f(x) = \frac{x^2 - 9}{x}$

59) _____

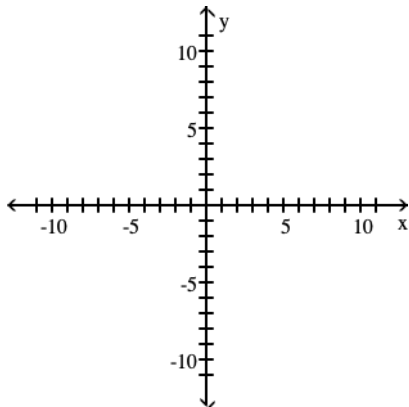

A)

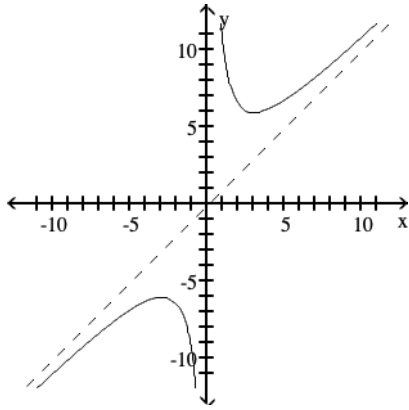

B)

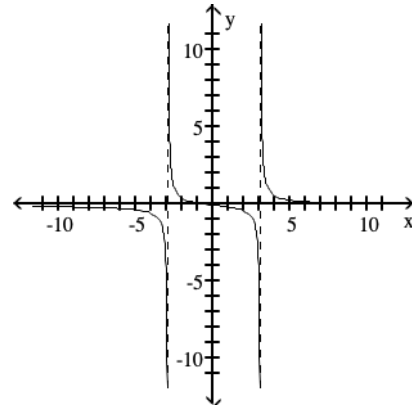

C)

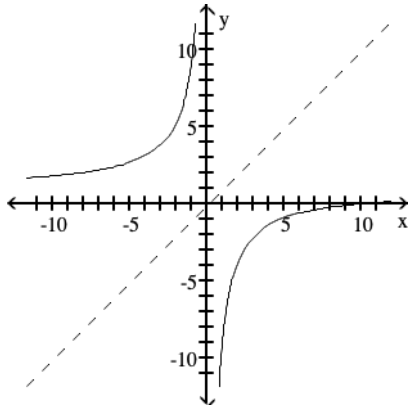

D)

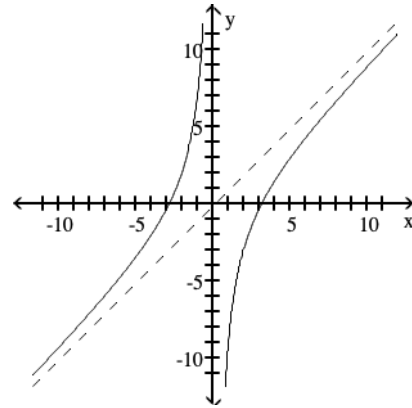

Approximate the number using a calculator. Round your answer to three decimal places.

60) $3^{-1.7}$

A) -4.913

B) 0.454

C) 0.154

D) -5.100

60) _____

Graph the function.

61) Use the graph of $f(x) = 5^x$ to obtain the graph of $g(x) = 5^x + 2$.

61) _____

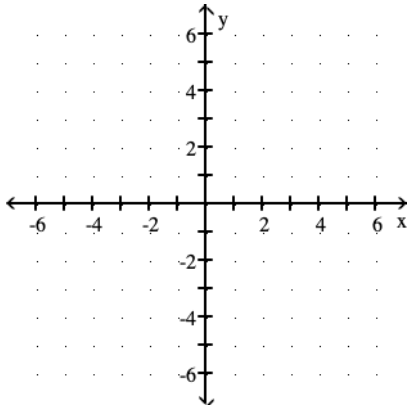

A)

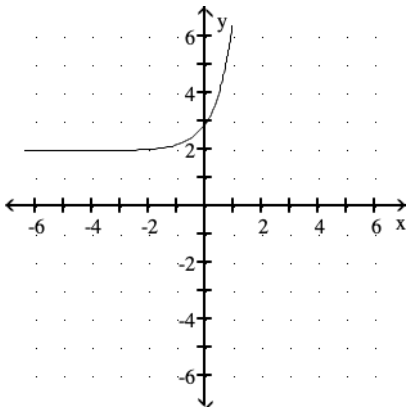

B)

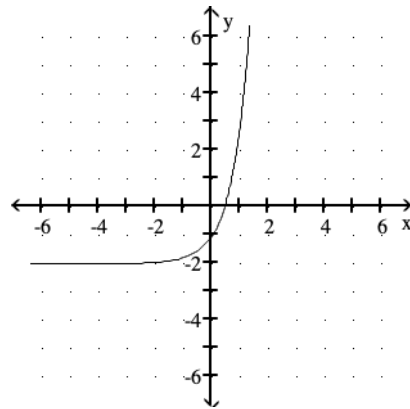

62) Use the graph of $f(x) = 5^x$ to obtain the graph of $g(x) = 5^{-x}$.

62) _____

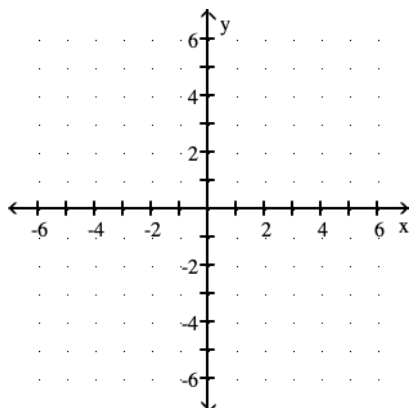

A)

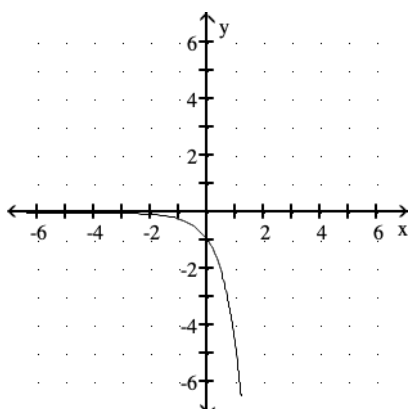

B)

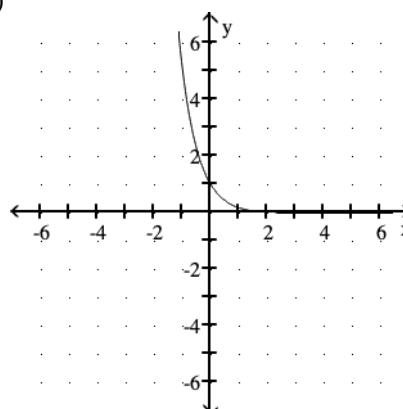

Approximate the number using a calculator. Round your answer to three decimal places.

63) $e^{1.2}$

A) 3.262

B) 3.620

C) 3.320

D) 1.641

63) _____

Solve the problem.

64) The growth in the mouse population at a certain county dump can be modeled by the exponential function $A(t) = 276e^{0.023t}$, where t is the number of months since the population was first recorded. Estimate the population after 14 months.

A) 381

B) 191

C) 390

D) 282

64) _____

65) The function $D(h) = 7e^{-0.4h}$ can be used to determine the milligrams D of a certain drug in a patient's bloodstream h hours after the drug has been given. How many milligrams (to two decimals) will be present after 11 hours?

A) 4.33 mg

B) 0.67 mg

C) 0.09 mg

D) 570.16 mg

65) _____

Solve the equation.

66) $4^{(3x - 5)} = 256$

A) $\{-3\}$

B) $\{128\}$

C) $\left\{\frac{1}{64}\right\}$

D) $\{3\}$

66) _____

67) $3^{-x} = \frac{1}{81}$ 67) _____

A) $\left\{\frac{1}{27}\right\}$ B) {4} C) {-4} D) $\left\{\frac{1}{4}\right\}$

Use the compound interest formulas $A = P\left(1 + \frac{r}{n}\right)^{nt}$ and $A = Pe^{rt}$ to solve.

68) Find the accumulated value of an investment of \$9000 at 4% compounded semiannually for 10 years. 68) _____

A) \$10,970.95 B) \$13,373.53 C) \$12,600.00 D) \$13,322.20

69) Find the accumulated value of an investment of \$1200 at 12% compounded quarterly for 6 years. 69) _____

A) \$2439.35 B) \$2064.00 C) \$2368.59 D) \$1432.86

70) Find the accumulated value of an investment of \$4000 at 8% compounded continuously for 4 years. 70) _____

A) \$5280.00 B) \$5508.51 C) \$5441.96 D) \$5608.51

71) Find the accumulated value of an investment of \$5000 at 5% compounded monthly for 8 years. 71) _____

A) \$7452.93 B) \$12,911.25 C) \$9093.60 D) \$8060.16

72) Suppose that you have \$12,000 to invest. Which investment yields the greater return over 8 years: 8.75% compounded continuously or 8.9% compounded semiannually? 72) _____

A) Both investment plans yield the same return.
 B) \$12,000 invested at 8.75% compounded continuously over 8 years yields the greater return.
 C) \$12,000 invested at 8.9% compounded semiannually over 8 years yields the greater return.

Convert to an exponential equation.

73) $\log_6 216 = 3$ 73) _____

A) $3^6 = 216$ B) $6^3 = 216$ C) $6^{216} = 3$ D) $216^3 = 6$

Write the equation in its equivalent exponential form.

74) $\log_5 25 = 2$ 74) _____

A) $2^5 = 25$ B) $25^2 = 5$ C) $5^{25} = 2$ D) $5^2 = 25$

Find the following using a calculator. Round to four decimal places.

75) $\log 0.41$ 75) _____

A) -0.8872 B) -0.3872 C) -0.3916 D) -0.8916

76) $\log (-4)$ 76) _____

A) 1.3863 B) 3 C) 1.6094 D) Does not exist

Solve the logarithmic equation. Be sure to reject any value that is not in the domain of the original logarithmic expressions. Give the exact answer.

77) $\log_2 (7x - 4) = \log_2 (3x + 3)$

77) _____

A) $\left\{\frac{7}{4}\right\}$

B) \emptyset

C) $\left\{-\frac{1}{4}\right\}$

D) $\{-1\}$

78) $\log_5 x^2 = \log_5 (6x + 27)$

78) _____

A) $\{9, -3\}$

B) \emptyset

C) $\{9\}$

D) $\left\{\frac{9}{5}\right\}$

Graph the function.

79) Use the graph of $\log_5 x$ to obtain the graph of $f(x) = \log_5 (x - 2)$.

79) _____

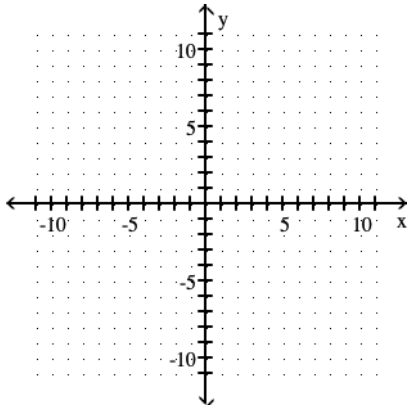

A)

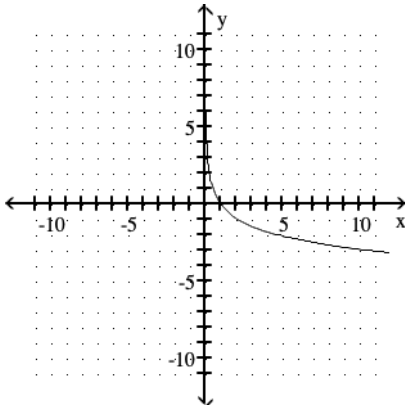

B)

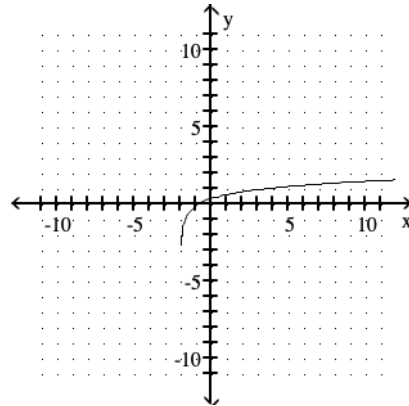

C)

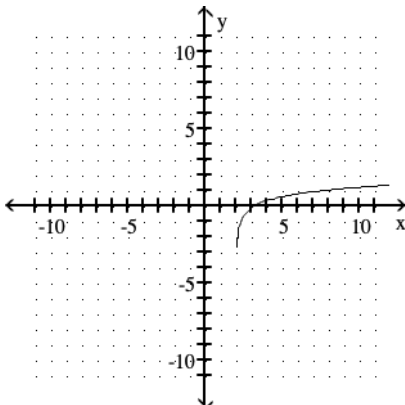

D)

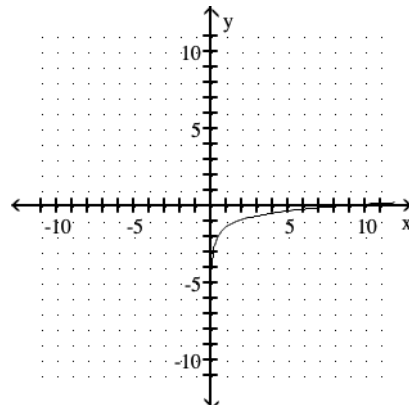

80) Use the graph of $\log_4 x$ to obtain the graph of $f(x) = -2 + \log_4 x$.

80) _____

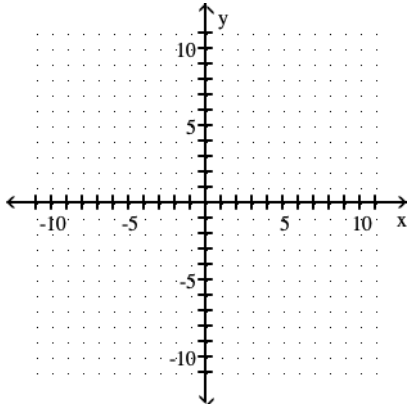

A)

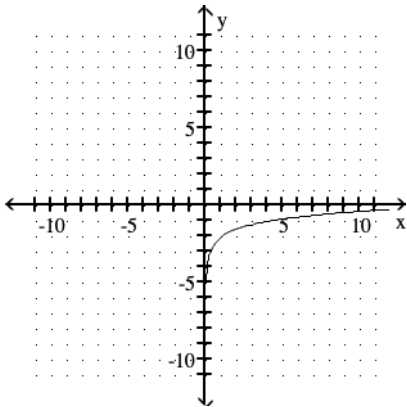

B)

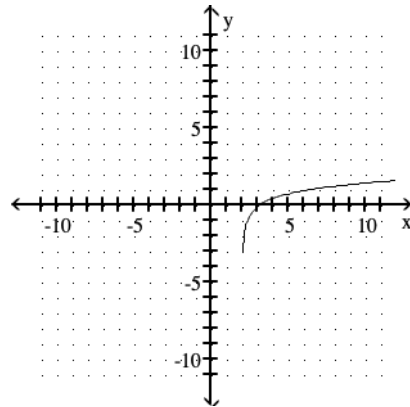

C)

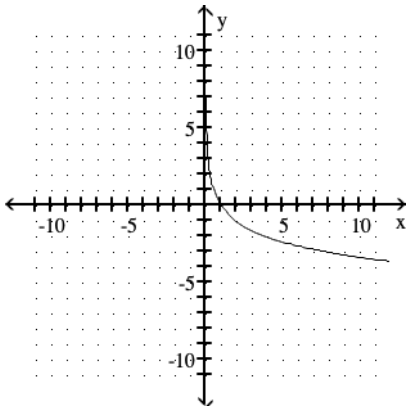

D)

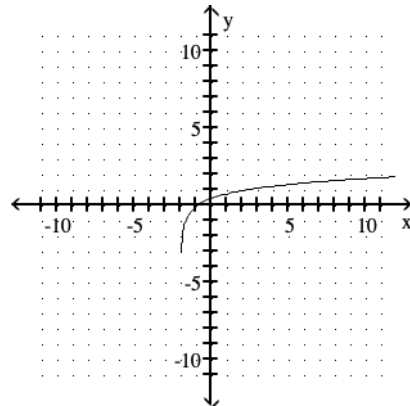

Find the following using a calculator. Round to four decimal places.

81) $\ln 0.991$

A) 0.0090

B) -0.0039

C) 0.0039

D) -0.0090

81) _____

82) $\ln 60,000,000$

A) 0.0557

B) 17.9099

C) 6.3969

D) 7.7782

82) _____

Solve the logarithmic equation.

83) $\log_{25} x = \frac{1}{2}$ 83) _____

- A) 0.00000003 B) 33,554,432 C) 625 D) 5

84) $\log_8 x = -5$ 84) _____

- A) 390,625 B) $\frac{1}{32,768}$ C) 32,768 D) $\frac{1}{390,625}$

85) $\ln x = 3$ 85) _____

- A) $\ln 3$ B) $3e$ C) 1000 D) e^3

Use common logarithms or natural logarithms and a calculator to evaluate to four decimal places

86) $\log_{13} 59.7$ 86) _____

- A) 0.6272 B) 2.8899 C) 0.6620 D) 1.5943

Use properties of logarithms to expand the logarithmic expression as much as possible. Where possible, evaluate logarithmic expressions without using a calculator.

87) $\log_3 (7 \cdot 11)$ 87) _____

- A) $(\log_3 7)(\log_3 11)$ B) $\log_3 7 + \log_3 11$
C) $\log_3 7 - \log_3 11$ D) $\log_3 77$

88) $\log_6 (6x)$ 88) _____

- A) 6 B) $1 + \log_6 x$ C) 1 D) x

89) $\log_4 (16x)$ 89) _____

- A) $2 + \log_4 x$ B) $2 \log_4 x$ C) $8 + \log_4 x$ D) $2x$

90) $\log_2 \left(\frac{2}{x} \right)$ 90) _____

- A) $-\log_2 x$ B) 2 C) $1 - \log_2 x$ D) $\frac{1}{x}$

91) $\log_3 \left(\frac{9}{x} \right)$ 91) _____

- A) $\frac{2}{x}$ B) $6 - \log_3 x$ C) $-2 \log_3 x$ D) $2 - \log_3 x$

92) $\log N^{-16}$ 92) _____

- A) $16 \log N$ B) $-16 + \log N$ C) $-16 \log N$ D) $16 + \log N$

93) $\log_b (yz^8)$ 93) _____
 A) $8 \log_b y + 8 \log_b z$ B) $\log_b y + \log_b 8z$
 C) $\log_b y + 8 \log_b z$ D) $8 \log_b yz$

94) $\log_4 \left(\frac{x^5}{y^7} \right)$ 94) _____
 A) $5 \log_4 x + 7 \log_4 y$ B) $\frac{5}{7} \log_4 \left(\frac{x}{y} \right)$
 C) $5 \log_4 x - 7 \log_4 y$ D) $7 \log_4 y - 5 \log_4 x$

Use properties of logarithms to condense the logarithmic expression. Write the expression as a single logarithm whose coefficient is 1. Where possible, evaluate logarithmic expressions.

95) $\log_3 (x + 3) - \log_3 (x + 5)$ 95) _____
 A) $\log_3 (x^2 + 8x + 15)$ B) $\log_3 \left(\frac{x + 3}{x - 5} \right)$
 C) $\log_3 -2$ D) $\log_3 \left(\frac{x + 3}{x + 5} \right)$

96) $2\log_b y + 4\log_b z$ 96) _____
 A) $\log_b (yz)^6$ B) $\log_b y^2 z^4$ C) $6\log_b yz$ D) $8\log_b yz$

Solve the equation by expressing each side as a power of the same base and then equating exponents.

97) $25^x + 6 = 125^x - 5$ 97) _____
 A) {21} B) {11} C) {27} D) {17}

Solve the exponential equation. Use a calculator to obtain a decimal approximation, correct to two decimal places, for the solution.

98) $2^{x+8} = 2$ 98) _____
 A) {9.00} B) {-0.90} C) {-7.00} D) {1.90}

99) $3^{(4x-1)} = 16$ 99) _____
 A) {1.58} B) {0.27} C) {0.88} D) {0.38}

Solve the exponential equation. Express the solution set in terms of natural logarithms.

100) $e^{5x} = 3$ 100) _____
 A) $\left\{ \frac{\ln 5}{3} \right\}$ B) {5 ln 3} C) $\left\{ \frac{3}{5} e \right\}$ D) $\left\{ \frac{\ln 3}{5} \right\}$

Solve the logarithmic equation. Be sure to reject any value that is not in the domain of the original logarithmic expressions. Give the exact answer.

101) $\ln x = 4$ 101) _____
A) $\{e^4\}$ B) $\{4e\}$ C) $\left\{\frac{4}{\ln 1}\right\}$ D) $\{\ln 4\}$

102) $\log_6 (x^2 - 5x) = 1$ 102) _____
A) $\{1\}$ B) $\{6, -1\}$ C) $\{-6, 1\}$ D) $\{6\}$

103) $\log_4 (x + 5) + \log_4 (x - 1) = 2$ 103) _____
A) $\{-7\}$ B) $\{3\}$ C) $\{3, -7\}$ D) $\{4\}$

104) $\log_8 (x + 2) - \log_8 x = 2$ 104) _____
A) $\left\{\frac{2}{63}\right\}$ B) $\left\{\frac{1}{32}\right\}$ C) $\{8\}$ D) $\left\{\frac{63}{2}\right\}$

105) $\log_4 (x - 2) - \log_4 (x - 5) = 2$ 105) _____
A) $\left\{\frac{26}{5}\right\}$ B) $\left\{-\frac{26}{5}\right\}$ C) $\left\{\frac{1}{5}\right\}$ D) \emptyset

106) $\ln 8 + \ln (x - 1) = 0$ 106) _____
A) $\{1\}$ B) $\left\{\frac{8}{9}\right\}$ C) $\left\{\frac{9}{8}\right\}$ D) $\left\{\frac{1}{8}\right\}$

107) $\log_6 x + \log_6 (x - 35) = 2$ 107) _____
A) $\{-1, 36\}$ B) $\{6\}$ C) $\{1, -36\}$ D) $\{36\}$

108) $\ln 7 + \ln (x - 1) = 0$ 108) _____
A) $\left\{\frac{1}{7}\right\}$ B) $\{1\}$ C) $\left\{\frac{8}{7}\right\}$ D) $\left\{\frac{7}{8}\right\}$

Answer Key

Testname: REVIEW FOR EXAM 2

- 1) B
- 2) D
- 3) A
- 4) A
- 5) D
- 6) B
- 7) D
- 8) C
- 9) A
- 10) A
- 11) D
- 12) D
- 13) A
- 14) A
- 15) B
- 16) C
- 17) A
- 18) B
- 19) C
- 20) D
- 21) C
- 22) A
- 23) B
- 24) B
- 25) C
- 26) B
- 27) D
- 28) D
- 29) B
- 30) A
- 31) B
- 32) B
- 33) C
- 34) C
- 35) B
- 36) A
- 37) B
- 38) C
- 39) D
- 40) B
- 41) B
- 42) C
- 43) A
- 44) B
- 45) A
- 46) A
- 47) C
- 48) D
- 49) A

Answer Key

Testname: REVIEW FOR EXAM 2

- 50) C
- 51) B
- 52) B
- 53) C
- 54) D
- 55) A
- 56) C
- 57) C
- 58) A
- 59) D
- 60) C
- 61) A
- 62) B
- 63) C
- 64) A
- 65) C
- 66) D
- 67) B
- 68) B
- 69) A
- 70) B
- 71) A
- 72) B
- 73) B
- 74) D
- 75) B
- 76) D
- 77) A
- 78) A
- 79) C
- 80) A
- 81) D
- 82) B
- 83) D
- 84) B
- 85) D
- 86) D
- 87) B
- 88) B
- 89) A
- 90) C
- 91) D
- 92) C
- 93) C
- 94) C
- 95) D
- 96) B
- 97) C
- 98) C

Answer Key

Testname: REVIEW FOR EXAM 2

- 99) C
- 100) D
- 101) A
- 102) B
- 103) B
- 104) A
- 105) A
- 106) C
- 107) D
- 108) C